

6
5
4
3
2
1

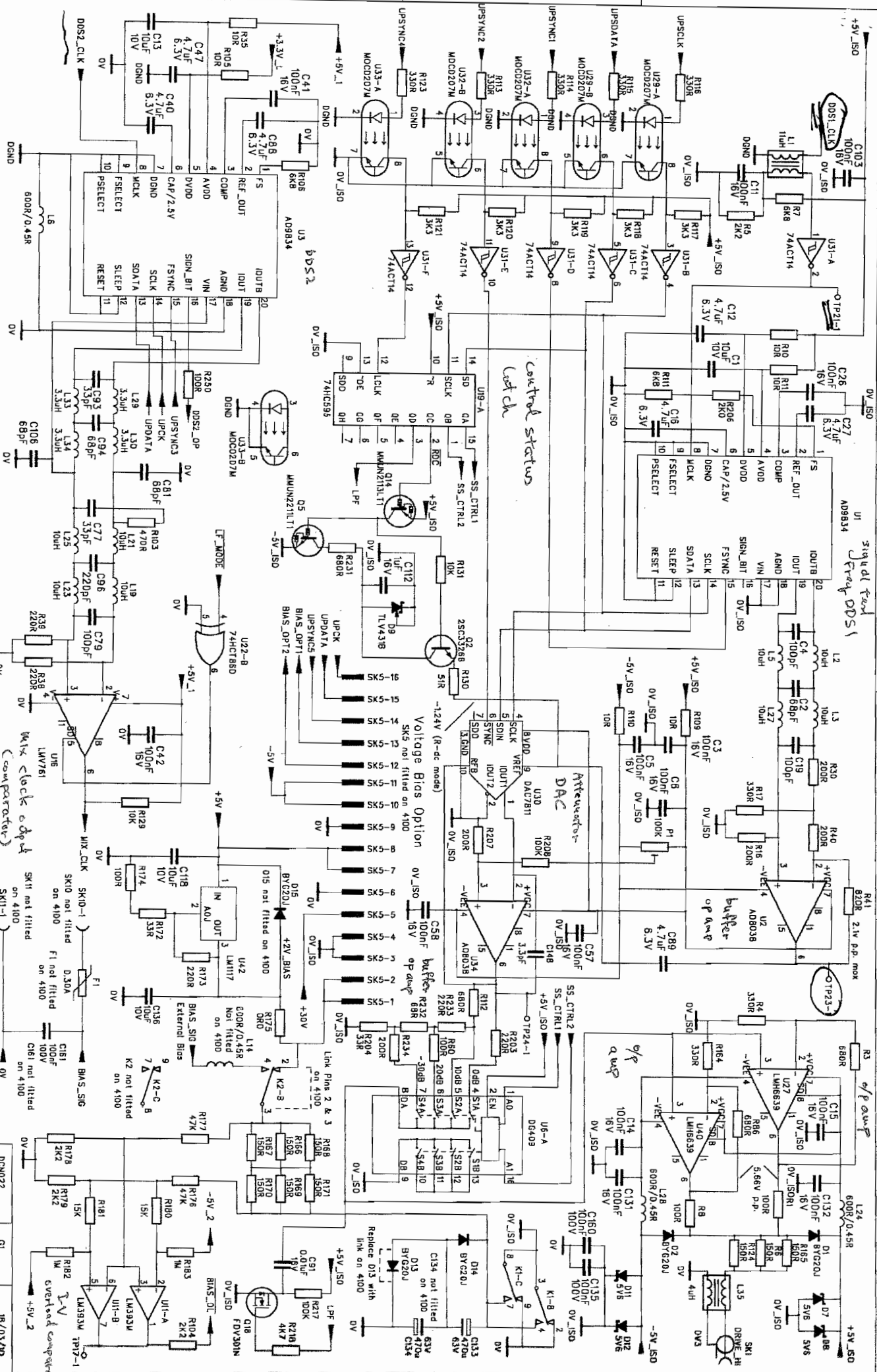

DRAWN: A.R.M.
 CHECKED: []
 APPROVED: []
 TITLE: SIGNAL SOURCE & MIXER DRIVE
 COPYRIGHT © WAYNE KERR ELECTRONICS 2008
 ALL RIGHTS RESERVED
 USED ON: 4300
 DRAWING NUMBER: 5-430-1000-02
 No: 1
 OF: 8
 CHANGE NO.: []
 ISSUE: []
 DATE: 1B/03/10
 WAYNE KERR ELECTRONICS

U3 DDS2 provides mix clock & ADC clock in new mix modes pin 16
 U2, U3 & U4 buffers opening
 U2, U3 & U4 buffers opening
 U2, U3 & U4 buffers opening

U11

U11

U11

U11

U11

U11

6
5
4
3
2
1

TP10, TP11, TP12, TP13, TP14, TP15

U37 Sense high buffer
U36 Sense low buffer
U38 Sense Lo buffer
U36 control amp for U38

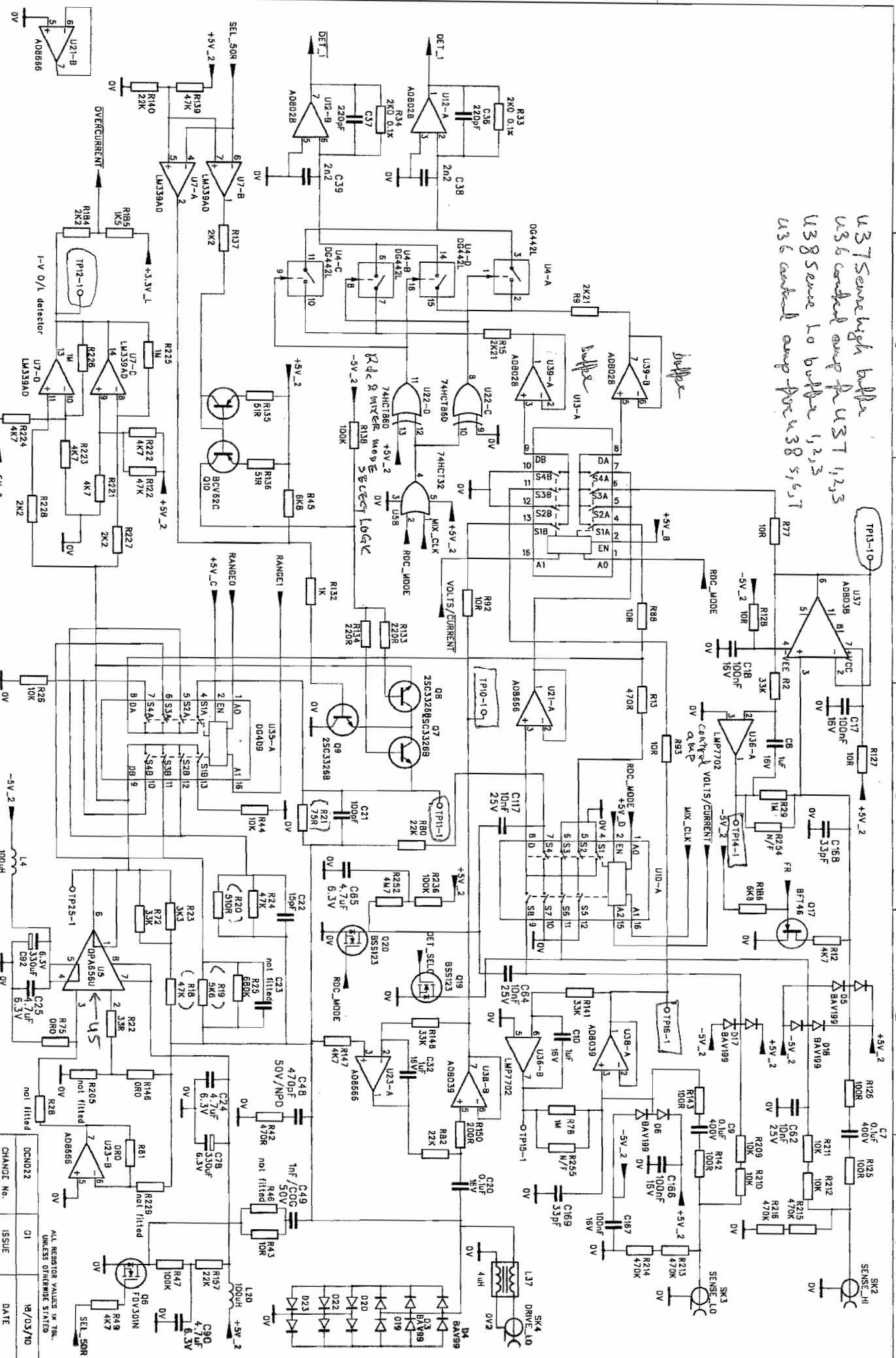

BRIDGE SECTION

DRAWN: A.R.M. | CHECKED: | APPROVED: | TITLE: BRIDGE SECTION

COPYRIGHT © WAYNE KERR ELECTRONICS 2008 | USED ON: 4300 | DATE: 10/03/10

ALL RIGHTS RESERVED | CHANGE NO. | ISSUE | DATE

DCND22 | 01

WAYNE KERR ELECTRONICS

U5 I-V Converter

CHANGE No.	ISSUE	DATE
DE022	GI	18/03/10

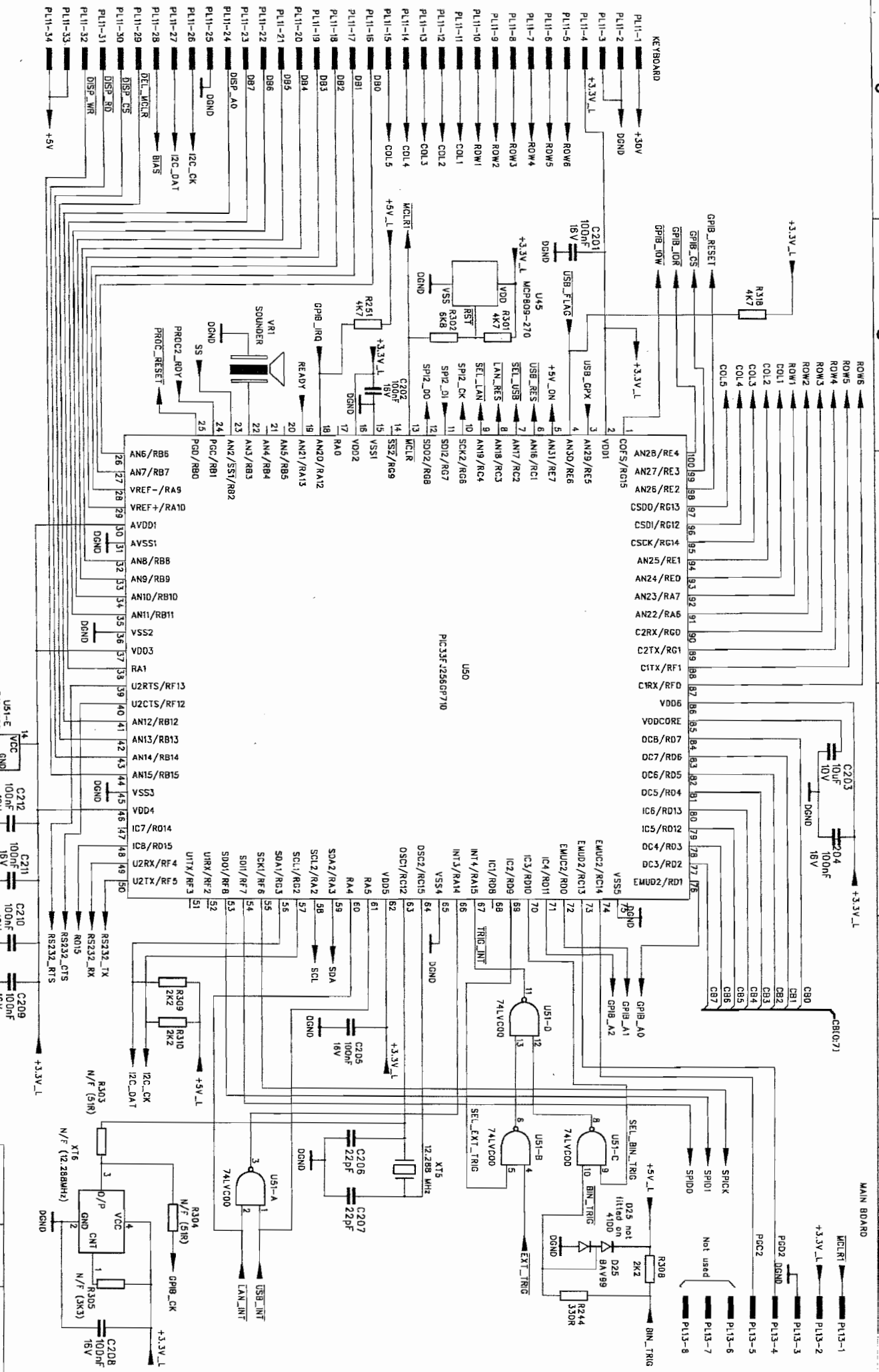

KEYBOARD
 P11-1
 P11-2
 P11-3
 P11-4
 P11-5
 P11-6
 P11-7
 P11-8
 P11-9
 P11-10
 P11-11
 P11-12
 P11-13
 P11-14
 P11-15
 P11-16
 P11-17
 P11-18
 P11-19
 P11-20
 P11-21
 P11-22
 P11-23
 P11-24
 P11-25
 P11-26
 P11-27
 P11-28
 P11-29
 P11-30
 P11-31
 P11-32
 P11-33
 P11-34

MAIN BOARD
 P113-1
 P113-2
 P113-3
 P113-4
 P113-5
 P113-6
 P113-7
 P113-8

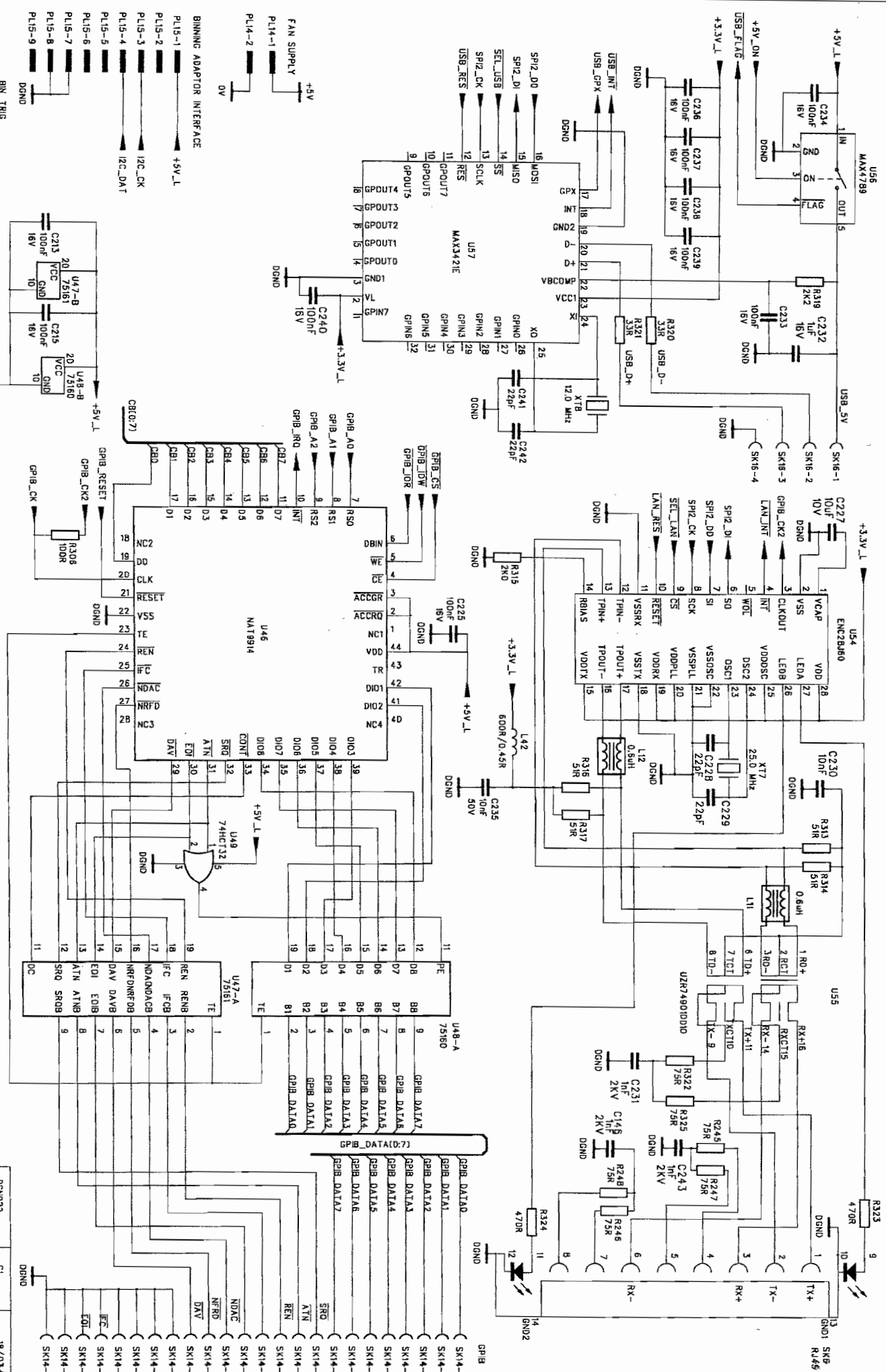

Components on this sheet are fitted for 4300 only. Not fitted on 4100.

DRAWN A.R.M.	CHECKED	APPROVED	TITLE USB/LAN/GPIB & BINNING	COPYRIGHT ©WAYNE KERR ELECTRONICS 2008 ALL RIGHTS RESERVED	USED ON 4300	DRAWING NUMBER 5-430-1000-02	No : 8 OF : 8	DCNO22	CHANGE No.	ISSUE	DATE 18/03/10
-----------------	---------	----------	---------------------------------	--	-----------------	---------------------------------	------------------	--------	------------	-------	------------------

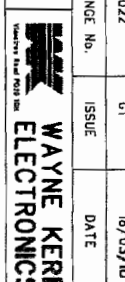

Quick Test Check list for 4300

- ✓ 1) Perform flash test and earth continuity checks *电压安全测试, 土壤离子.*
- ✓ 2) Check mains supply outputs *测试电源.*
- ✓ 3) Perform mains voltage sweep 90V-265V check +/-5V outputs *测试点图.*
- ✓ 4) Check DC levels in instrument *测试DC Level.*
- 5) Check output signal source ranging 2V, 1V, 0.4V, 0.2V, 0.1V, 40mV, 20mV and 10mV. *2V.*
- ✓ 6) Check signal source frequency (20Hz, 150Hz, 1KHz, 10KHz 100KHz, 1MHz) *6格 示波器 放大器.*
- 7) Set 2V @ 1KHz into open circuit. Check Sense Hi signal level relative to signal source TP13 *放大器 6格.*
- 8) Swap sense hi and Sense Lo leads check Sense Lo. TP16 *放大器 6格.*
- 9) Set freq to 20Hz. Check Sense Lo TP16 and level on TP15. Swap leads back again. *记得电容没有坏. C10. C8.*
- 10) Check Sense Hi TP13 and level on TP14. *3:1*
- ✓ 11) Apply short circuit. Check signal at ripple rejector TP22. *测试到 x1. 看波动情况 示波器测试/校准. 和开路短路.*
- ✓ 12) Set freq to 1KHz. Set range to 4 and check overload comparator TP12. Reduce level to 350mV and recheck. *在真有效值模式下. short circuit. 0.33V. 0.34V.*
- 13) Set level to 2V and range to Auto. Check signal level on I-V U5 Pins 1 or 6 (should be about 4.5V p.p.)
- 14) Check I-V (U5) output level on TP11
- 15) Check level on Detector outputs to ADC TP 19 and TP 20 (about 1.15V p.p.)
- 16) Remove short and recheck (about 1.5V p.p.) Change frequency to 4KHz - should give about 2.15Vp.p.
- 17) Drop frequency to 60Hz check 2.2V p.p. Change frequency to 500Hz and recheck for same level.
- 18) Set range to Auto check open circuit at 1KHz should read about 80M ohm. (2pF of 1006)
- 19) Apply short circuit and check values at 20Hz, 120Hz 1KHz, 4KHz < 2mΩ
- 20) Perform short circuit trim. Check that the short circuit is < 250μΩ @ 20Hz, < 200μΩ at 120Hz, 1KHz, 4KHz and 10KHz.
- 21) Perform open circuit trim. Check that the open circuit is > 5GΩ @ 20Hz, 120Hz, 1KHz, 4KHz and 10KHz
- 22) Select R-dc mode @ 1V and 2V. Check open circuit resistance > 2GΩ and short circuit resistance < 500μΩ.
- ✓ 23) Insert 220uF capacitor. Set to C & D and apply internal bias. Check bias voltage and general measurement.
- ✓ 24) Select Ext bias and apply 35V from power supply. Check bias output on 1006.
- ✓ 25) Check bias overload comparator as bias is switched on and off. Restore Bias to internal.
- ✓ 26) Check GPIB, using PC.
- ✓ 27) Check USB using a memory stick. Select Ethernet. Select Status menu and check software issues.
- ✓ 28) Return from status menu and check LAN connection. Return instrument to normal mode.
- ✓ 29) Check External trigger by connecting a 50Ω terminator on and off to the BNC connector.
- ✓ 30) Select Buzzer. Press each button in turn to check button function. Turn off instrument and reboot with a button pressed to get default setup.
- 31) Select 1V signal and 1KHz Check performance using resistor values 1Ω, 10Ω, 100Ω, 1KΩ, 100KΩ, 1MΩ.
- 32) Repeat above procedure for R-dc mode.
- 33) Using 100Ω and 1KΩ with 4300 set for R & Q check performance at 20Hz, 30KHz, 100KHz and 1MHz.
- 34) Use 1nF check C & D at 20Hz, 1KHz 10KHz, 100KHz and 1MHz.
- 35) Repeat using 10nF for 20Hz, 1KHz, 10KHz and 100KHz.
- ✓ 36) Heat soak instrument. *40°C.*

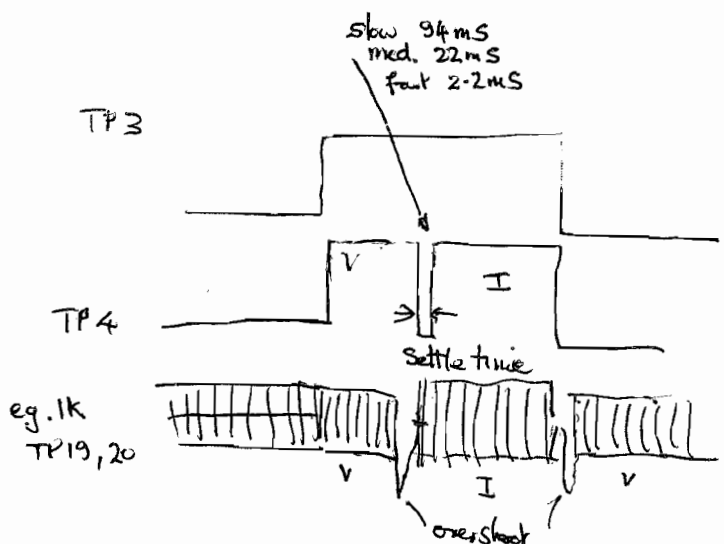



TEST & CALIBRATION PROCEDURE 4300 SERIES

INTRODUCTION

SHORT PRE TEST

This document is the specification for the 4300 Test Procedure for Wayne Kerr Electronics Limited. The contents of this procedure are the property of Wayne Kerr Electronics Limited and shall not be copied, used or otherwise disclosed to others, unless so authorised in writing by the Company.

Prepared By:

A.R.Miller
Engineering

Approved By:

W.Griffiths
Test / Production



4300 Precision Component Analyser
Test & Calibration Procedure

WK_TP_79
Issue B

13/04/10

Page 2 of 8

AMENDMENTS:

AMENDMENT NUMBER	DATE	SECTION	ENTERED BY
B	8/1/09	Rewrite of pre-test and functional test sections.	A.R.M.



TEST SPECIFICATION FOR 4300

1. TEST EQUIPMENT

1.1 TEST EQUIPMENT SPECIFICATIONS

Item No.	Description	Quantity/Specification	Quantity	Typical Equipment
1	Standards	<p>Screened , 4-terminal Standards terminated in 4 BNC connectors. Screens connected together at Standard .</p> <p>R Values. Known values are relative to S/C Low inductance bulk metal film resistors.</p> <p>1.00Ω ±1% R known to ±0.005% L " " ±1nH</p> <p>10.00Ω ±1% R " " ±0.005% L " " ±10nH</p> <p>100.00Ω ±1% R " " ±0.005% L " " ±100nH</p> <p>1.00kΩ ±1% R " " ±0.005% L " " ±1μH</p> <p>10.00kΩ ±1% R " " ±0.005% C " " ±0.1pF</p> <p>100.0kΩ ±1% R " " ±0.005% C " " ±0.01pF</p> <p>1MΩ ±1% R " " ±0.005% C " " ±1fF</p> <p>C Values. Known values are relative to O/C</p> <p>1.0nF ±2% polystyrene *</p> <p>1.0nF ±1% silver mica C known to ±0.01%</p> <p>10nF ±2% polystyrene *</p> <p>100pF ±1% silver mica C known to ±0.01% @10kHz D known to ±0.0001 @10kHz</p> <p>* Dissipation Factor known to ±0.0001 at 100Hz and 10kHz</p>		WK Secondary Stds. Box with calibration values stored on USB Flash Memory
2	Transfer Standard	100R metal film resistor	1	
3	Transfer Standard	10R metal film resistor	1	
4	Transfer Standard	47pF polystyrene capacitor	1	
5	Transfer Standard	10μH Air cored toroid	1	
6	Transfer Standard	1μH Air cored toroid	1	
7	Oscilloscope	BW:350MHz min. Sensitivity:10mV/div to 5V/div. Input Impedance ≥1MΩ min	1	Tektronix
8	Scope Leads	x1 / x10	2	
9	AC/DC Voltmeter	BW : 3MHz min Accuracy : 0.2 %	1	Rhode & Schwarz URE2

Description	Quantity/Specification	Quantity	Typical Equipment
DC Voltmeter	Range: 100V Accuracy: $\pm 1\%$	1	Keithley 2000 Multimeter
DC Ammeter	Range: 1A Accuracy: $\pm 0.2\% \pm 10\mu\text{A}$	1	Keithley 2000 Multimeter
Frequency Meter	Range: 10kHz Accuracy: 10ppm	1	Keithley 2000 Multimeter
HV Flash Tester	2.1kVdc. 0.5mA current trip	1	
Continuity tester.	25A into 0.5Ω min @ line frequency	1	Irwin EAO799
Variac	Min 200VA/>265V max	1	
Test Lead	Screened 50Ω with two BNC connectors	2	
Test Lead	Standard GPIB cable	1	
Test Leads	4mm to 4mm lead pair (red/black)	2	
Programmer	Microchip Real ICE emulator/programmer	1	
Computer	Desktop/Laptop with GPIB and RS232 ports. The following test software should be preloaded. MPLAB IDE National Instruments Measurement and Automation software V2 Wayne Kerr RS232 Test program Wayne Kerr test schedule for 4300.	1	
Test Lead	Standard LAN cable	1	
Network Port	10/100-BASETX Ethernet Connection	1	
USB Memory		1	
Power Supply	Triple General Purpose Variable Power supply 0-30V @ 1A	1	
Test Lead	Power lead connector set for 4300	1	
Kelvin Test Leads	1EVA40150	1	
1K resistor	1K, 0.1% metal film leaded	1	
Power Supply	General Purpose Variable Single Power Supply 0-30V @ 1A	1	
Test connector	4mm female to coax male	1	
Test Fixture	W-K model 1006	1	
Dummy Front Panel	Front Panel assembly of 4300 including leads	1	
Short Circuit	Short Circuit to DRG 4-654-6038	1	
Test Chassis	Front Panel Board Test	1	
RS232 Cable	Standard RS232 Cable 9 way male 'D' to 9 way female 'D'	1	



Turn off the power.

2.1 PROGRAMMING CONTROL PROCESSOR

In MPLAB IDE open the Control Processor Project and connect the Real ICE emulator (19) to the computer (20). Ensure that the project is in 'Release Mode' and that the Real ICE is set up for 'Programming Mode'. Connect the emulator pod to PL2 on the main board. (The component side of the emulator pod should face the front of the main board). Configure the link (PL4) to connect between pins 2 and 3. Restore the power to the main board. Program the Control Processor firmware by entering in 'Program' in the drop down box on the IDE and note that the message box should indicate 'Programming/Verify successful'. If there is any message such as 'cannot recognise Real ICE' try removing the power and removing/reinserting the USB cable to the Real ICE pod, restore the power and try again. If a message such as 'cannot detect object at expected address 0x.....' Check that the Real ICE has been plugged into the correct connector and is correctly orientated. After programming remove the power, and disconnect the Real ICE pod.

2.2 PROGRAMMING THE MASTER PROCESSOR

This procedure is done in a similar manner to the Control Processor programmed previously. In MPLAB IDE close the previous project and then open the **MAIN Processor Test** Project with the Real ICE emulator connected to the computer. Remove the power. As before, ensure that the project is in 'Release Mode' and that the Real ICE is set up for 'Programming Mode'. Connect the emulator pod to PL13 on the main board and restore the power. (The component side of the emulator pod should face the front of the main board). Now configure the link (PL4) to connect between pins 1 and 2. **Be very careful to ensure that the emulator pod is *not* connected to PL2 as before, as attempts to program the wrong code into the wrong processor can be successful and will usually damage the Control Processor as a result.** Any message such as 'cannot detect object at expected address 0x.....' should be treated with extreme caution before proceeding further. When satisfied that all is well, program in the code, remove the power and disconnect the Real ICE pod.

2.3 DC CHECKS

Now connect a working front panel assembly (31).

Using the connector (25), setup the +5V, -5V and 30V supply for the display. Then using the Digital Voltmeter (10) Check the supply levels at the following positions on the board.

- 2.3.1.1 Check the internal bias supply at pin 3 (tab) of the regulator U42 / anode of D15 to be +2V +/- 0.12V
- 2.3.1.2 Check the ripple rejection supply at the drain of Q11 (TP22). This should read 4.96V +/- 0.05V.
- 2.3.1.3 Check the +3.3V supply at regulator U52 pin 2 (tab) positive end of C219 to be 3.3V +/- 0.16V.
- 2.3.1.4 Test the Sense High amplifier output voltage, (TP13), the Sense Low voltage (TP16) to be zero +/- 3mV and the Drive Low buffer output voltage (TP10) also to be zero +/- 5mV.
- 2.3.1.5 Check the dc offset of U36 pin 7 at TP15. This usually reads about -0.25V. Also check TP14 (U36 pin 1). The offset should be roughly the same. A wide range is tolerable on these offset voltages, but if the voltage is in excess of +/-2.5V suspect a fault.
- 2.3.1.6 Check the DC potential of the detector output to be 2.5V +/- 0.15V at test points TP19 and TP20.
- 2.3.1.7 Select AC impedance mode, 1KHz @ 0.65V and repeat trigger. Measure the dc output voltage to be 0V +/- 20mV.
- 2.3.1.8 Select R-dc mode. First select 1V then select 2V. Check that the output voltage is correct within +/-5%. (+/-0.05V +/-0.1V)
- 2.3.1.9 Finally check the input power requirements with the display operating. The +5V requirement should be 680mA +/-80mA and the negative, -5V requirement should be 320mA +/- 60mA.

The part-tested main board is now ready to be inserted into the metalwork of the unit.

2.4 TESTING THE FRONT PANEL ASSEMBLY

Since this board is a separate sub-assembly it can be tested in any part of the early sequence, but for convenience is listed here.

- 2.4.1.1 Connect the assembly to the test chassis (33) using a 34 way ribbon cable assembly. Power up the test chassis.
- 2.4.1.2 Check that a display can be observed on the LCD panel. Check that the contrast level can be adjusted from dark grey to pale white using the push button controls.
- 2.4.1.3 Select buzzer mode on the test chassis and hence check all the push buttons for functionality SW1-SW30.
- 2.4.1.4 Check that the Green power indicator LED is lit and that the red BIAS ON indicator is lit when the Bias button is pressed.
- 2.4.1.5 Check the Pixel quality of the display. No more than 2 faulty pixels allowed. No faulty pixels adjacent to each other.



2.5 ASSEMBLY OF UNIT

The 4300 principal boards should now be assembled into the metalwork, viz. Power Supply, Main Board and Front Panel Assembly. Connect the 4 BNC cables from the main board to the Front Panel sockets, the 34 way ribbon connector between the Main board and the Front Panel Board, and the power cable between the Power supply board and the Main board.

3. FLASH TEST AND CONTINUITY

This section of the test procedure should be carried out in a designated area with clear notice of a high voltage test taking place. Only personnel trained in the use of the test equipment should carry out this section of the procedure.

3.1 SET-UP

Fit two 1.6A slow blow fuses into the fuse holder tray of the IEC connector at the rear of the unit. Turn the power switch ON, checking the mechanical operation of the power switch.

3.2 FLASH TEST

3.2.1.1 Using Flash Tester (20), flash test at 500Vdc between L and N shorted together and E. (1mA trip). **Record the result**

3.3 EARTH BONDING

3.3.1.1 Using the Continuity tester (14), carry out 25A continuity test between E and exposed metalwork (NOT BNC outer). Disconnect the earth bonding tester and turn the power switch off. **Record the result**

POWER SUPPLY TESTS

3.4 SETUP

Connect the instrument to the Variac (15) with the voltage set to 0V. Turn the instrument power switch on. Increase the variac voltage to 90v rms.

3.5 POWER SUPPLY TESTS

This roughly checks that the power supply voltages are present before connecting to the Main Board.

3.5.1.1 Check that all 5 indicator LED's are lit on the power supply board.

3.5.1.2 Check that the loaded voltages lie within the range on the table below.

Rail	Measurement points (PL1)	Nominal Voltage (Vdc)	Minimum Voltage	Maximum Voltage
+5V	Pins 3-4 wrt pin 2	+5V	+4.75	+5.25
-5V	Pins 7-8 wrt pin 2	-5V	-4.75	-5.25
+30V	Pin 1 wrt pin 2	+33V	+29V	+37V
+5V ISO	Pin 9 wrt pins 10-11	+5V	+4.75V	+5.25V
-5V ISO	Pin 12 wrt pins 10-11	-5V	-4.75V	-5.25V

3.5.1.3 Increase the voltage to 265V rms. Check that each of the rails is within the specifications as given above.

3.5.1.4 Remove the Variac and connect the instrument to the normal mains supply.

3.6 INSTRUMENT ANALOGUE & DIGITAL FUNCTIONAL TESTS

3.6.1.1 Connect the oscilloscope (7) to the Signal Source (yellow) front panel socket. Select AC impedance mode, 1KHz frequency, 2V output and repeat trigger mode. Set the oscilloscope to 1V/div, dc coupling and then trigger to display the waveform. The signal should measure about 5.7V peak-peak with little or no offset. Now reduce the 4300 signal to 0.4V and the oscilloscope to 0.2V/div. The signal should read 5.7 divisions (0.57V peak-peak).

3.6.1.2 Remove the oscilloscope, set the 4300 output level to 2V and connect a counter timer (12) to the yellow front panel socket. Check that the counter timer records the frequencies (within ± 50 ppm) for 20Hz, 1KHz and 100KHz.

3.6.1.3 Connect a 1006 4-terminal test fixture (30) to the front panel sockets. Select 20Hz on the 4300 with repeat trigger and 2V output.





2.5 ASSEMBLY OF UNIT

The 4300 principal boards should now be assembled into the metalwork, viz. Power Supply, Main Board and Front Panel Assembly. Connect the 4 BNC cables from the main board to the Front Panel sockets, the 34 way ribbon connector between the Main board and the Front Panel Board, and the power cable between the Power supply board and the Main board.

3. FLASH TEST AND CONTINUITY

This section of the test procedure should be carried out in a designated area with clear notice of a high voltage test taking place. Only personnel trained in the use of the test equipment should carry out this section of the procedure.

3.1 SET-UP

Fit two 1.6A slow blow fuses into the fuse holder tray of the IEC connector at the rear of the unit. Turn the power switch ON, checking the mechanical operation of the power switch.

3.2 FLASH TEST

3.2.1.1 Using Flash Tester (20), flash test at 500Vdc between L and N shorted together and E. (1mA trip). **Record the result**

3.3 EARTH BONDING

3.3.1.1 Using the Continuity tester (14), carry out 25A continuity test between E and exposed metalwork (NOT BNC outer). Disconnect the earth bonding tester and turn the power switch off. **Record the result**

POWER SUPPLY TESTS

3.4 SETUP

Connect the instrument to the Variac (15) with the voltage set to 0V. Turn the instrument power switch on. Increase the variac voltage to 90v rms.

3.5 POWER SUPPLY TESTS

This roughly checks that the power supply voltages are present before connecting to the Main Board.

3.5.1.1 Check that all 5 indicator LED's are lit on the power supply board.

3.5.1.2 Check that the loaded voltages lie within the range on the table below.

Rail	Measurement points (PL1)	Nominal Voltage (Vdc)	Minimum Voltage	Maximum Voltage
+5V	Pins 3-4 wrt pin 2	+5V	+4.75	+5.25
-5V	Pins 7-8 wrt pin 2	-5V	-4.75	-5.25
+30V	Pin 1 wrt pin 2	+33V	+29V	+37V
+5V ISO	Pin 9 wrt pins 10-11	+5V	+4.75V	+5.25V
-5V ISO	Pin 12 wrt pins 10-11	-5V	-4.75V	-5.25V

3.5.1.3 Increase the voltage to 265V rms. Check that each of the rails is within the specifications as given above.

3.5.1.4 Remove the Variac and connect the instrument to the normal mains supply.

3.6 INSTRUMENT ANALOGUE & DIGITAL FUNCTIONAL TESTS

3.6.1.1 Connect the oscilloscope (7) to the Signal Source (yellow) front panel socket. Select AC impedance mode, 1KHz frequency, 2V output and repeat trigger mode. Set the oscilloscope to 1V/div, dc coupling and then trigger to display the waveform. The signal should measure about 5.7V peak-peak with little or no offset. Now reduce the 4300 signal to 0.4V and the oscilloscope to 0.2V/div. The signal should read 5.7 divisions (0.57V peak-peak).

3.6.1.2 Remove the oscilloscope, set the 4300 output level to 2V and connect a counter timer (12) to the yellow front panel socket. Check that the counter timer records the frequencies (within ± 50 ppm) for 20Hz, 1KHz and 100KHz.

3.6.1.3 Connect a 1006 4-terminal test fixture (30) to the front panel sockets. Select 20Hz on the 4300 with repeat trigger and 2V output.



- 3.6.1.4 Insert a short circuit (32) into the 1006. Check the ripple output of the filtered supply at TP22 (Q11 drain). This should show very little ripple or 20Hz frequency (<2mV). This can be checked with the oscilloscope on 2mV/div and the probe set to x1 position.
- 3.6.1.5 Set the 4300 to 1KHz with repeat trigger and 2V output. Keep the short circuit in the 1006 and set the 4300 range to 4.
- 3.6.1.6 Connect a x10 probe to the oscilloscope probe with the attenuator set to give 2V/div at the probe tip. Connect the probe to TP12 and a 2KHz rectangular waveform should exist from +3.3V to -5V. Now drop the 4300 signal amplitude. At about 340mV the output from the comparator should be observed to become stable at +3.3V.
- 3.6.1.7 Set the 4300 to range 3 @ 1KHz frequency and 2V signal level. Set the oscilloscope attenuator to give 1V per division at the probe tip.
- 3.6.1.8 Connect the probe to the I-V opamp U5 output pin 6 (or pin1 – a convenient via hole exists close to pin1). The signal level should indicate a 1KHz sine wave of amplitude approximately 4.5V peak to peak. It should not exceed 4.9V p.p. as this will trip the overload comparator. A likely fault would then exist with the current switch Q7-Q9.
- 3.6.1.9 Now monitor the standard resistor level at TP11. This should be close to 4.24V p.p.
- 3.6.1.10 Set the 4300 speed to slow and with the short circuit still in the 1006 measure the outputs from the detector at TP19 and 20. The signal at both points should be the same. It should show a narrow burst of 1KHz with an amplitude of approx. 1.15V p.p. at a dc bias voltage of 2.5V
- 3.6.1.11 Now remove the short in the 1006. The detector outputs at TP19 and 20 should now show a wider burst with an amplitude of approx. 1.5V p.p. Increase the 4300 frequency to 4KHz and this burst amplitude should be approx. 2.2V p.p.
- 3.6.1.12 Now reduce the 4300 frequency to 60Hz. Again the burst amplitude should be 2.2V p.p.
- 3.6.1.13 Re-check with the 4300 at 500Hz. Again the amplitude should be approx. 2.2V. These tests check that the detector ac-coupling time constants are being selected correctly.
- 3.6.1.14 With the short circuit still in the 1006, check the untrimmed short circuit at 20Hz, 120Hz, 1KHz, and 4KHz to be < 2mΩ.
- 3.6.1.15 Now perform an open circuit and short circuit trim. Check the short circuit to be <250μΩ at 20Hz, and <200μΩ at 1KHz and 4KHz. Similarly check that the open circuit impedance is >5GΩ at these frequencies.
- 3.6.1.16 Switch to R-dc mode. Select 1V output level and slow speed. Insert the short in the 1006 and check the short circuit resistance to be < 500μΩ.
- 3.6.1.17 Remove the short circuit and check the high impedance at 1V. This should be >2GΩ.
- 3.6.1.18 Insert a 220μF 50V electrolytic capacitor into the 1006 (positive end of the capacitor to the 1006 terminal marked 'BIAS'). Select C and D measurement in the 4300 with frequency at 1KHz, signal level at 1V and the ranging to Auto. Speed should be slow and repeat trigger should be selected.
- 3.6.1.19 Select internal bias mode and press the BIAS button. The red bias light should illuminate and a 'CHARGING' message should briefly appear on the screen. Using the digital volts meter (10) measure across the terminals of the 1006. This should indicate 2V ± 5%.
- 3.6.1.20 Now turn the bias off and in the menu select 'EXT BIAS'. Set the power supply (28) to 30V and connect the test leads (18) to the respective DC bias input sockets at the rear of the 4300. Red to +30V, black to 0V.
- 3.6.1.21 Now select bias on and using the DVM (10) check the voltage across the 1006 terminals. This should read close to 30V.
- 3.6.1.22 Turn off the bias and re-check this voltage. It should now be close to zero.
- 3.6.1.23 Using the oscilloscope (7) and probe (8) check the bias overload comparator, U11 pins 1,7 at test point TP17. When the bias button is pressed each time and the capacitor is charged and discharged the comparator should trip for a few mS. When the comparator trips, the voltage will go down to -5V and then rise to +3.3V at the end of the period. It will be observed that the bias relays give a double click sound when the bias is turned off.
- 3.6.1.24 Remove the capacitor and insert a 1KΩ resistor (27) into the 1006. Set the 4300 to AUTO, SLOW, 1V @ 1KHz and to display R and Q. The reading should indicate close to 1KΩ and the Q value should be close to zero.
- 3.6.1.25 Re-check with the previous set up with the 4300 set to 20Hz, 150Hz, 20KHz, 100KHz. Note that Q will increase at 20Hz in an uncalibrated instrument.
- 3.6.1.26 Insert a 100Ω resistor (38) into the 1006 and similarly check at 20Hz, 150Hz, 1KHz, 20KHz and 100KHz.
- 3.6.1.27 Select R-dc mode and measure the 1KΩ and 100Ω again with slow speed selected at 1V and 2V. All readings should correspond with the resistor values.



Check the various Rear Panel I/O functions as listed.

NETWORK

- 3.6.1.28 Connect the network cable (21) into the network port (22). Use the scroll bar in the main menu to select **Ext Control** in the **OPTION** menu. The select **NET**. On pressing the **ENTER** key watch carefully the bottom of the display. This should show a statement such a "**connected in 5mS**". If a statement such as "**timed out**" appears, then there may be a fault with the circuit.

USB

- 3.6.1.29 Disconnect the network cable and connect a USB memory stick (23) into the USB socket. Select USB under the **Ext Control** menu and the 4300 should recognise a "high speed device" connected to the port. Remove the memory stick and the message should then show "device disconnected".

GPIB

- 3.6.1.30 Connect the GPIB cable (17) to the rear panel socket and also to the Laptop computer (20).
- 3.6.1.31 Select GPIB in the 4300 options menu.
- 3.6.1.32 Boot up the National Instruments Measurement and Automation software and select "**Devices and Interfaces**"
- 3.6.1.33 Next select "GPIB0" and "scan for devices". A message should appear "**Wayne Kerr 4300 at address 6**"

RS232

- 3.6.1.34 Remove the GPIB cable and connect the RS232 cable (34). Select the W-K RS232 test program.
- 3.6.1.35 Select RS232 in the 4300 options menu.
- 3.6.1.36 Run the RS232 test program to check the port.
- 3.6.1.37 Remove the cable and in the 4300 External Control menu select "OFF" to disable external control.

EXTERNAL TRIGGER

- 3.6.1.38 Select a convenient AC test mode and single trigger mode using the Sni/Rep button. Connect a piece of wire between the inner and outer of the rear panel **TRIGGER IN** BNC so that it allows a momentary short. Check that the instrument triggers each time a connection is made. Remove the wire.
- 3.6.1.39 Press the Trigger button on the front panel. Check that the instrument triggers each time the button is pressed.
Remove any rear panel external connections remaining.

The instrument is now ready to be heat soaked prior to final test. This should be done for approximately 6 hours at 40°C.

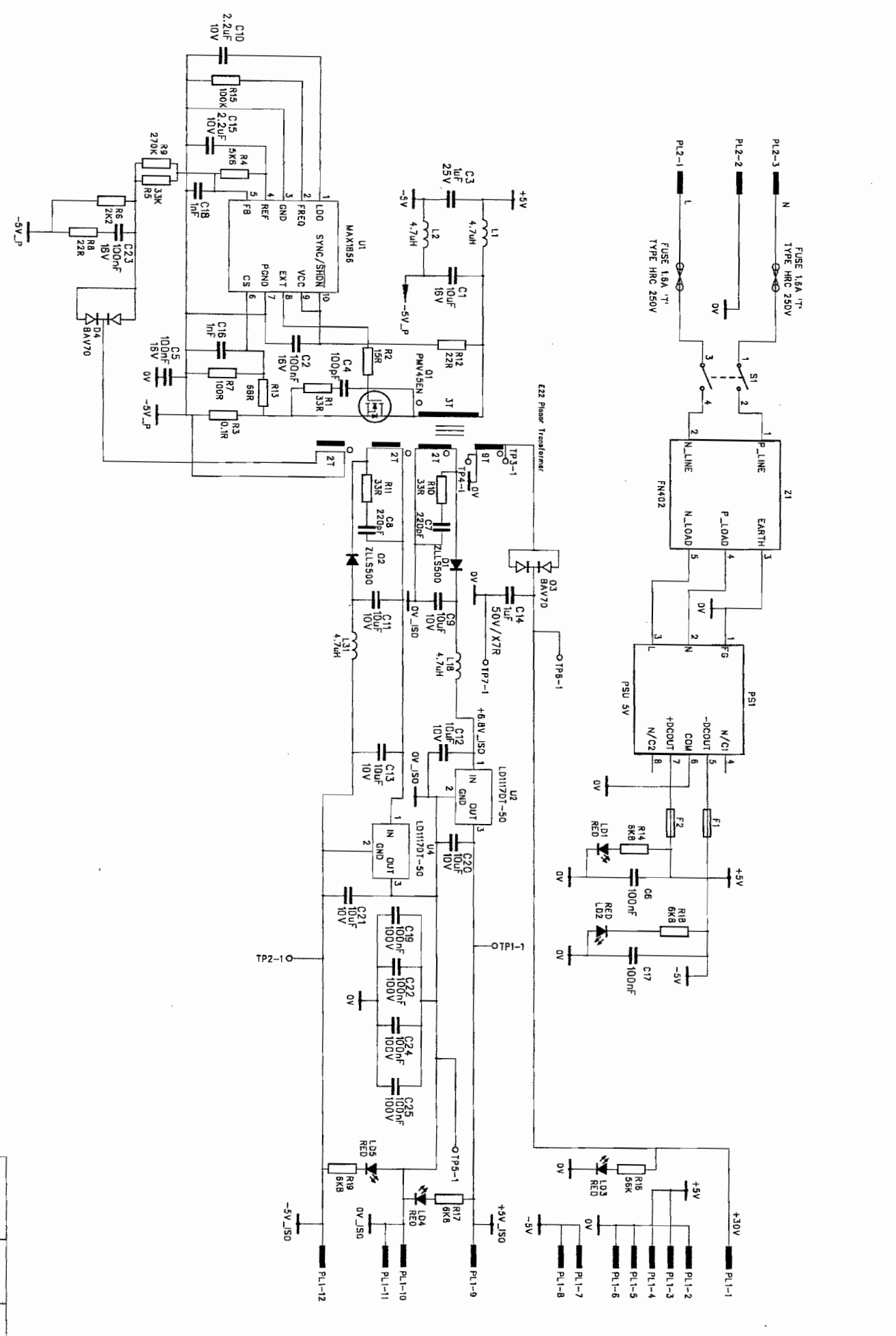

DRAWN A.R.M.	CHECKED	APPROVED	TITLE POWER SUPPLY	COPYRIGHT © WAYNE KERR ELECTRONICS 2006 ALL RIGHTS RESERVED	USED ON 4300	DRAWING NUMBER 5-430-1010-02	ALL RESISTOR VALUES IN Ω, UNLESS OTHERWISE STATED.	DCND1B	0	05/03/09
								CHANGE NO.	ISSUE	DATE
								WAYNE KERR ELECTRONICS		

PROCESSOR BOARD

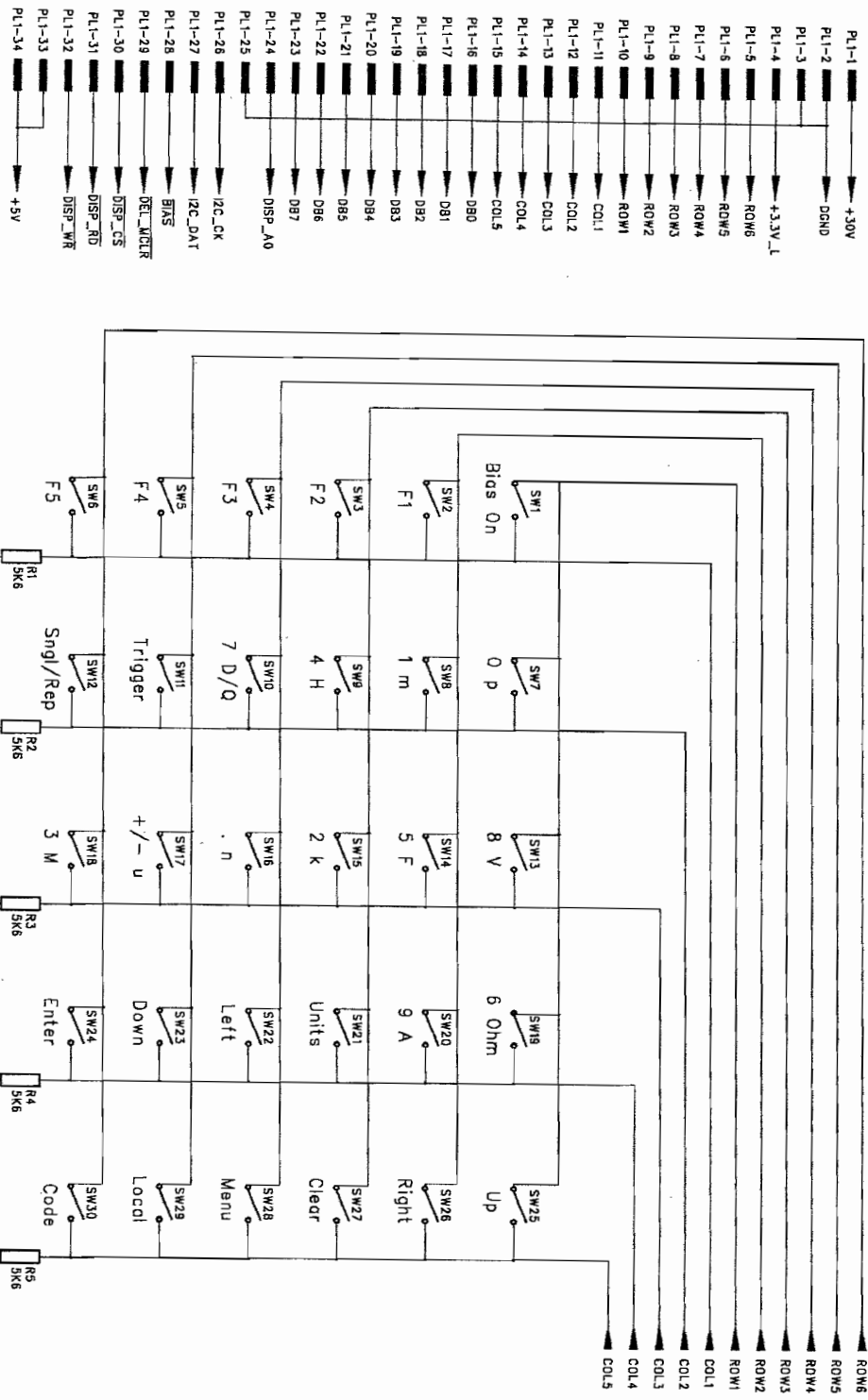

KEYBOARD ENCODING

DRAWN	CHECKED	APPROVED	TITLE
A.R.M.			KEYPAD SCHEMATIC

COPYRIGHT © WAYNE KERR ELECTRONICS 2006 ALL RIGHTS RESERVED

USED DN 4300

DRAWING NUMBER 5-430-1005-02

No: 1 OF: 2

DCN08	B	21/08/08
CHANGE No.	ISSUE	DATE
WAYNE KERR ELECTRONICS		

ALL RESISTOR VALUES IN TOH UNLESS OTHERWISE STATED

u42 mode of D15

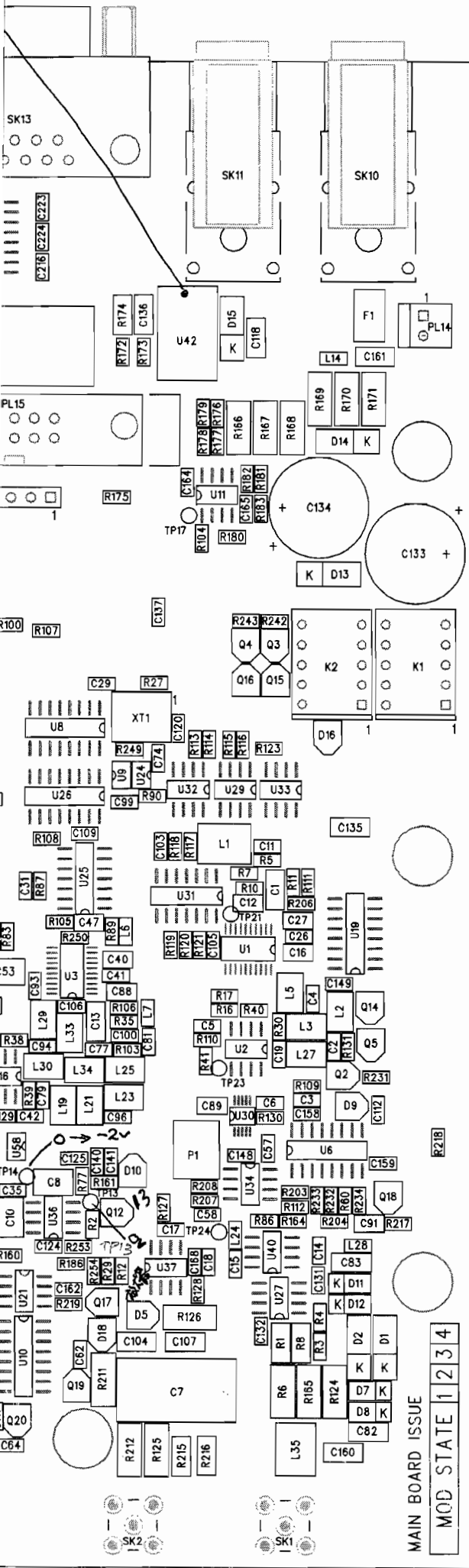

Functions

u8, u26. frequency dividers 0.32768 MHz
3.726 MHz
16.384 MHz

- XT1 32.768 MHz clock chip main frequency generator
- u25 gating logic for u8/u26.
- u9 inverter, u24 bistable relocking logic
- u31 Schmitt trigger buffer for opto-couplers u29, u33, u32
- u19 control status latch
- u1 signal test frequency DDS1
- u2 } buffer op amp
- u34 }
- u30 Attenuator DAC.
- u6 Attenuator 0, 10, 20, 30dB Analog switch
- u27/u40 output amplifier.

Signal Source

- u16 Mix clock output (comparator)
- u11 I-V overload comparator
- u3 DDS2 provides mix clock & {ADC clock in non-mix modes} pin 16.

Bridge

- u37 sense high buffer
- u36 control amplifier for u37 pins 1, 2, 3
- u38 pins 1, 2, 3 sense L_o buffer
- u36 control amp for u38 pins 5, 6, 7
- u36 pins 5, 6, 7 Drive L_o buffer
- u5 I-V converter R18 = 47K } high accuracy
R19 = 5K } ranging resistors
R20 = 510R
R21 = 75Ω
- Q7, Q8, Q9 + Q10 = switch for 75Ω (R21)
- u35 switch for R18, R19, R20

- u15 = ADC.
- u10 = RDC mixer (500Hz)
- u13 = volts/current selector
- u22 = Rdc & mix mode select logic
- u39 dual buffer amp
- u4 mixer for measurement channel
- u12 mixer buffer
- u17 5, 6, 7 differential to single-ended converter
- u18 0, 10dB, 20dB attenuator
- u17 1, 2, 3 x 8 amplifier
- u20 12, 13, 14 10:1/1:1 signal switch
- u20 3, 4, 5 & 1, 2, 3 settling time constant switch
- u28 1, 2, 3 ADC1 amplifier / HF filter
- u28 5, 6, 7 ADC2 amplifier / LF filter

h. 28 kHz
50
540

MIX MODE

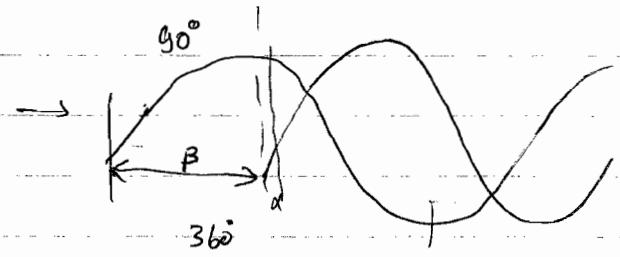
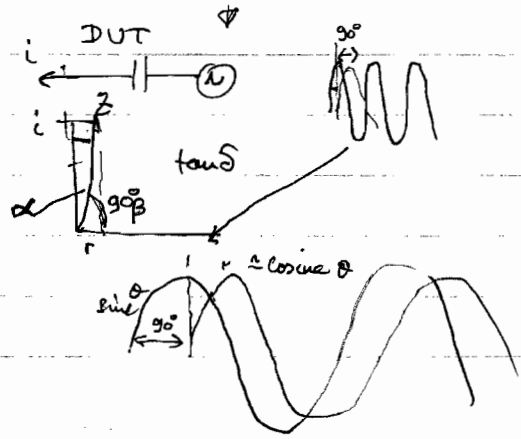
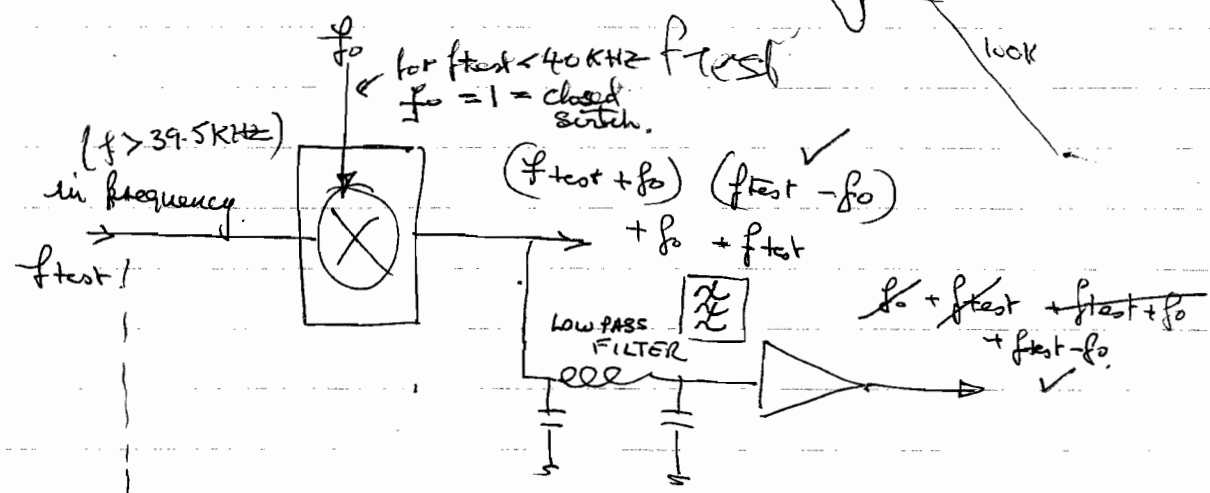
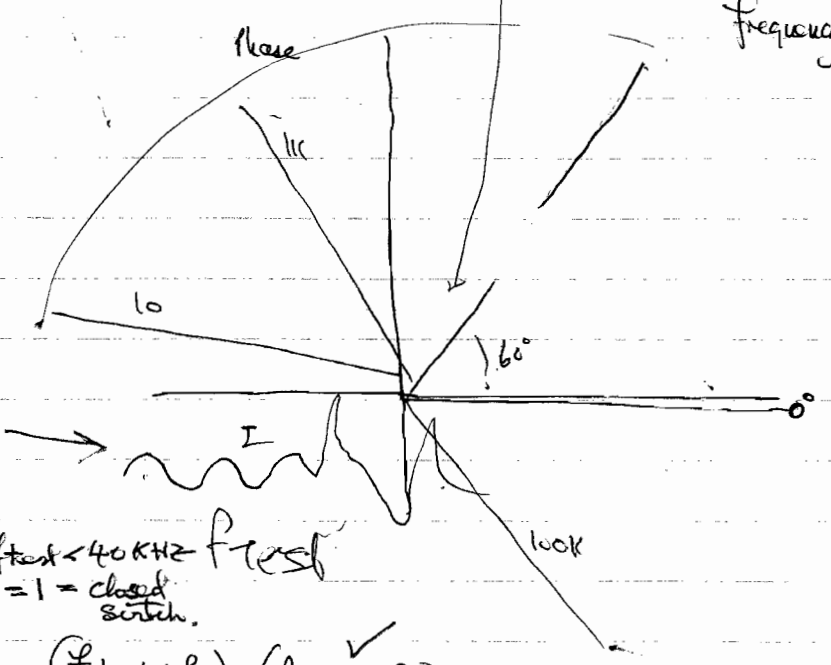
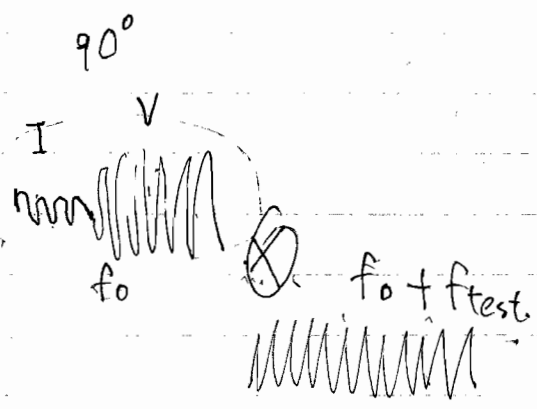
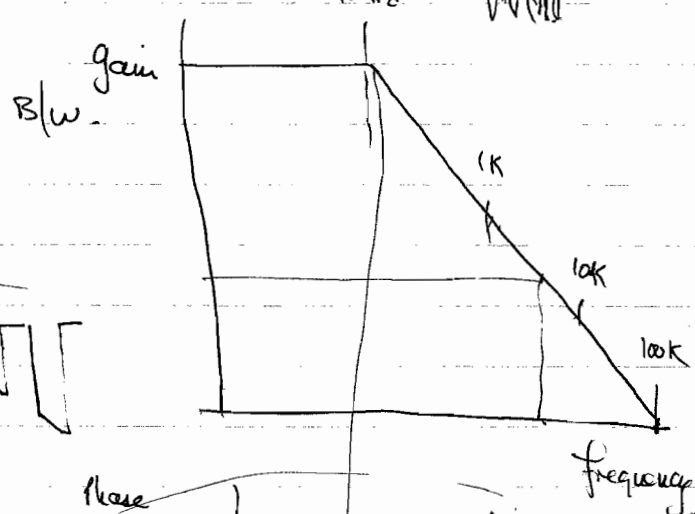
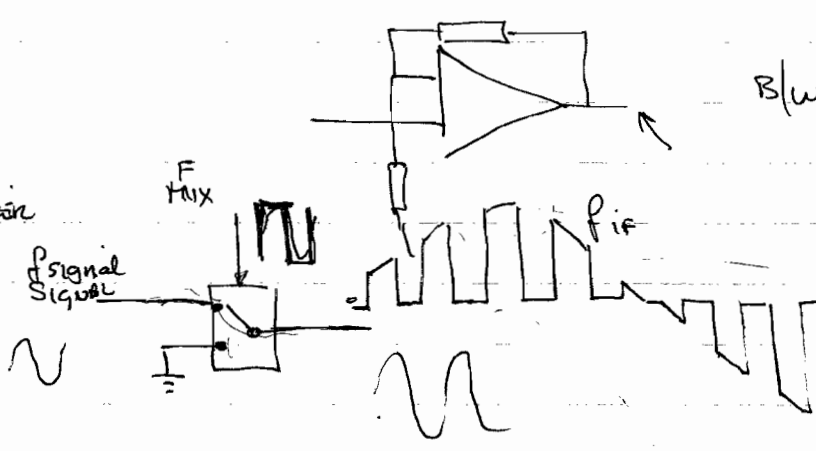

如卖方不能按合同规定交货或不能交货时，除一般公认的不可抗力原因外，卖方应按迟交或不能交货部分总值的 0.5%（每周）罚款赔偿给买方，此项罚款总额不超过全部迟交合同货物总值的 5%

18. ARBITRATION 仲裁:

All disputes in connection with this Contract or the execution thereof shall be settled through friendly negotiations. If no settlement can be reached, the case in dispute shall be submitted to the foreign trade arbitration commission of the China council for the promotion of international trade in accordance with the provisional rules of procedures promulgated by the said arbitration commission. The arbitration shall take place in Beijing and the decision made by the arbitration commission shall be accepted as final and binding upon both parties; neither party shall seek recourse to a law court nor other authorities to appeal for revision of the decision. Arbitration fee shall be borne by the losing party.

凡有关执行合同所发生的一切争执，双方须通过友好协商解决。双方如协商不能解决时，此争执应提交中国国际贸易促进会仲裁委员会按照该委员会颁布的仲裁程序暂行条例进行仲裁。仲裁在北京进行，仲裁委员会的裁决为终局裁判，双方均受其约束，仲裁费用由败诉方负担。

19. EFFECTIVENESS 合同生效:

This Contract comes into force after signature by both parties. This Contract is made in three original copies, two copies to be held by buyer and one copy by seller in witness thereof.

本合同由双方签字之日起生效。合同正本一式三份，由买方执两份卖方执一份。

The Buyer:

CHANGCHUN MECHANICAL EQUIPMENTS I/E CO.,LTD

The Seller:

Wayne Kerr Electronics Int.

WORCUM, MA 01091

UNITED STATES OF AMERICA

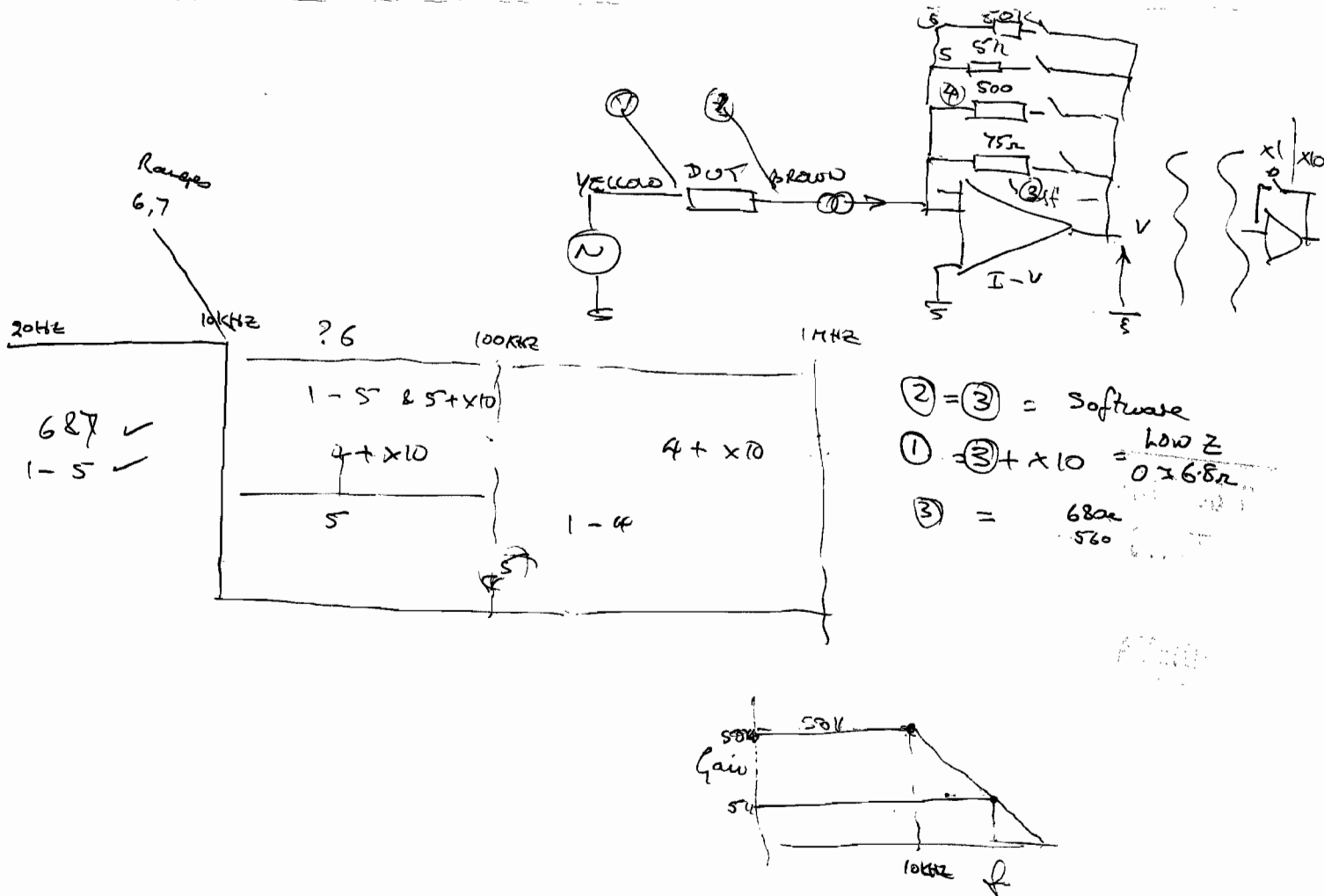

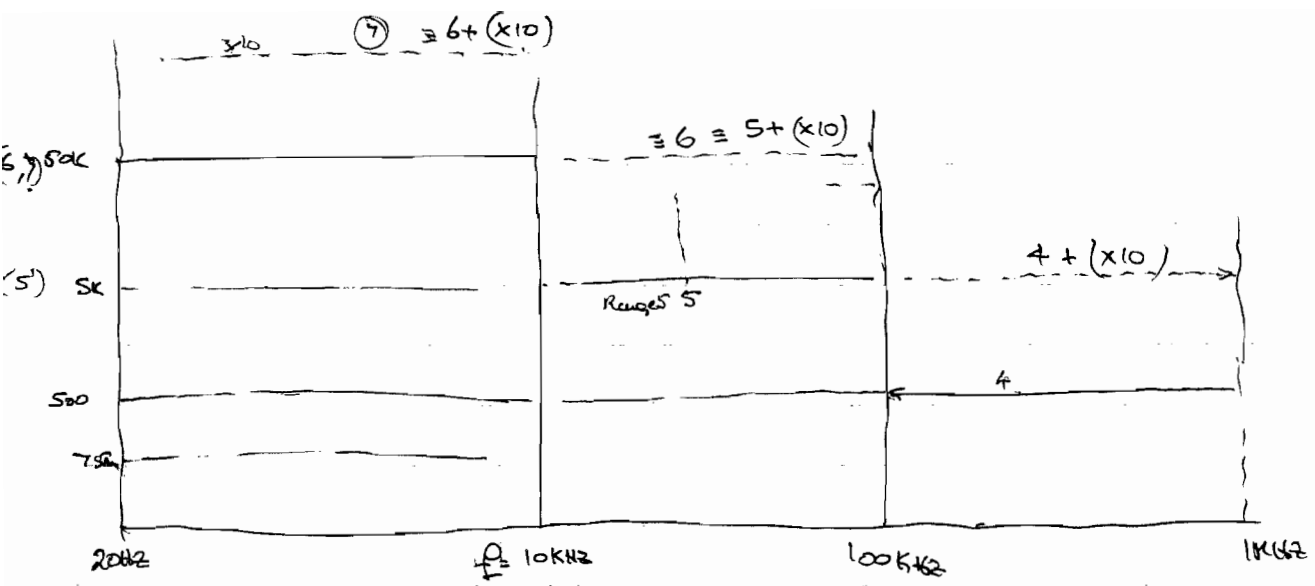

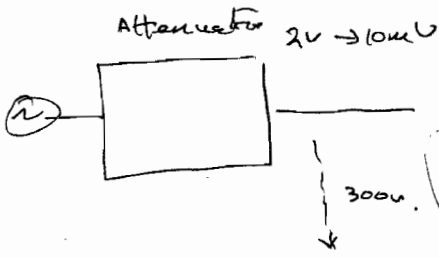

$D = \frac{1}{\phi}$

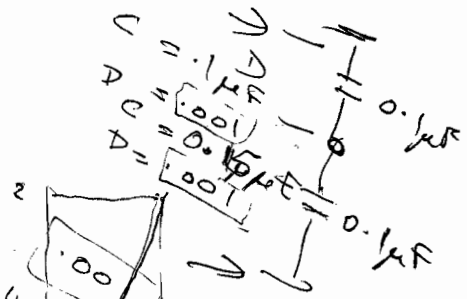

DETECTOR

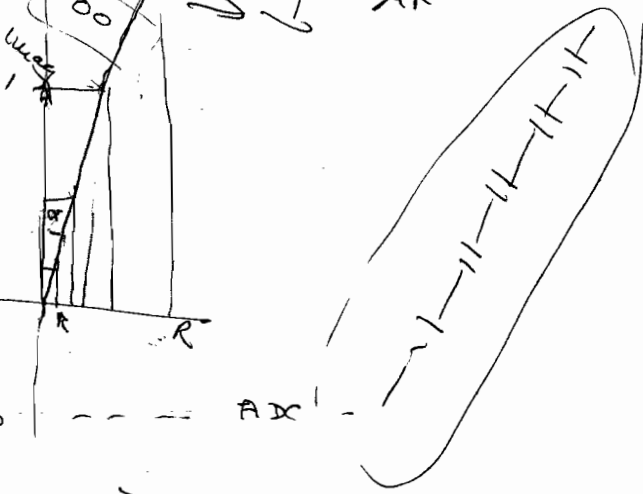
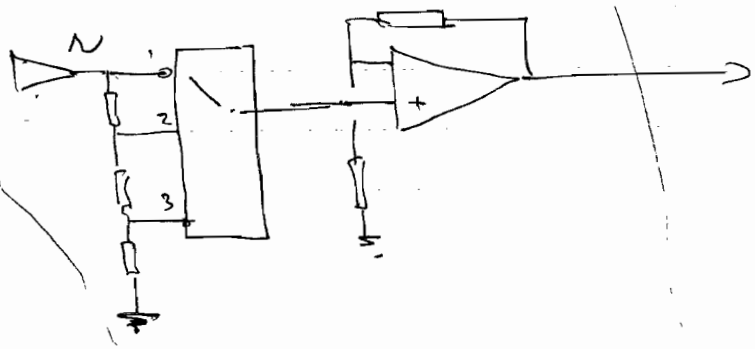

$X_c = \frac{1}{2\pi f C}$

$C = \frac{C}{2} = \frac{2}{\omega C}$

$\frac{1}{\omega C}$

.0001 ←

.00015

0.15 x x mR

176, pR
 255 pR

- .00000
- .0001
- .0002
- .0003

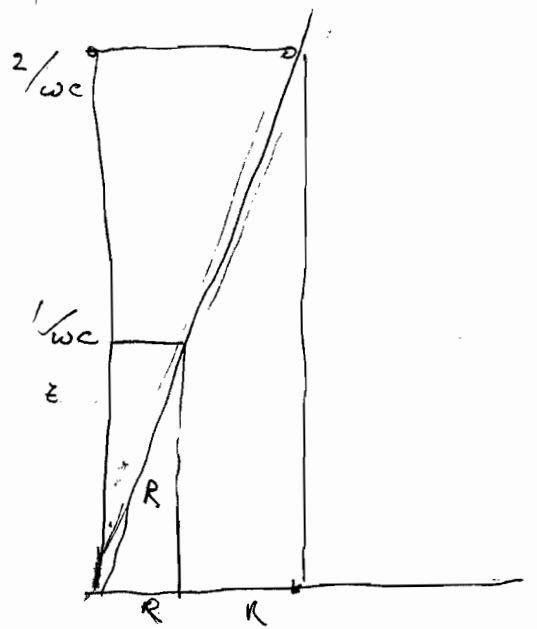

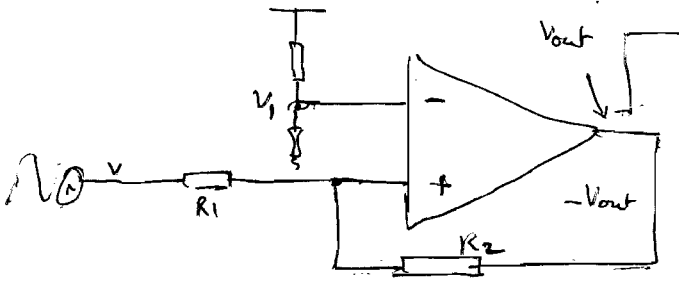
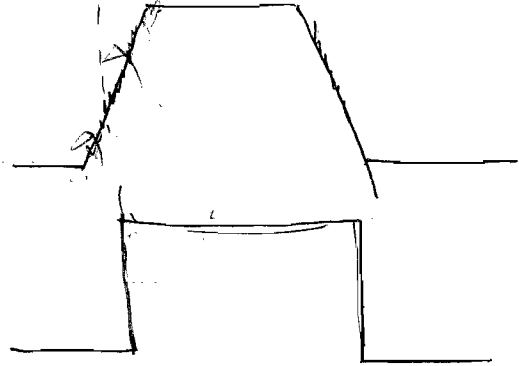
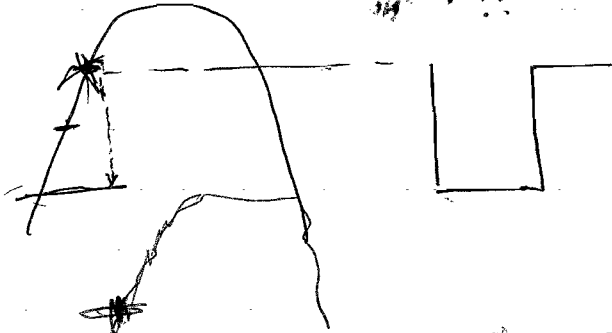

hysteresis

high.

$$V_{out} \times \frac{R_1}{R_1 + R_2} + V_1$$

low

$$-V_{out} \times \frac{R_1}{R_1 + R_2} + V_1$$

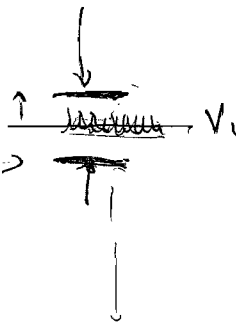

$$V \Rightarrow I$$

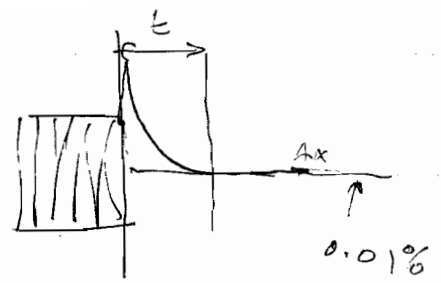
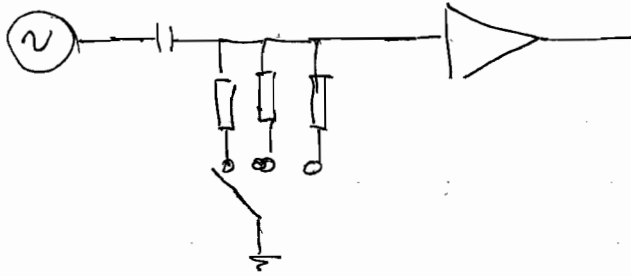

$$V = V_0 e^{-t/RC}$$

- @ 20kHz Dead time = 90ms, 2x 47ms.
 100kHz " " = 22ms, 2x 11ms
 1kHz " " = 2.4ms, 2x 1.2ms.

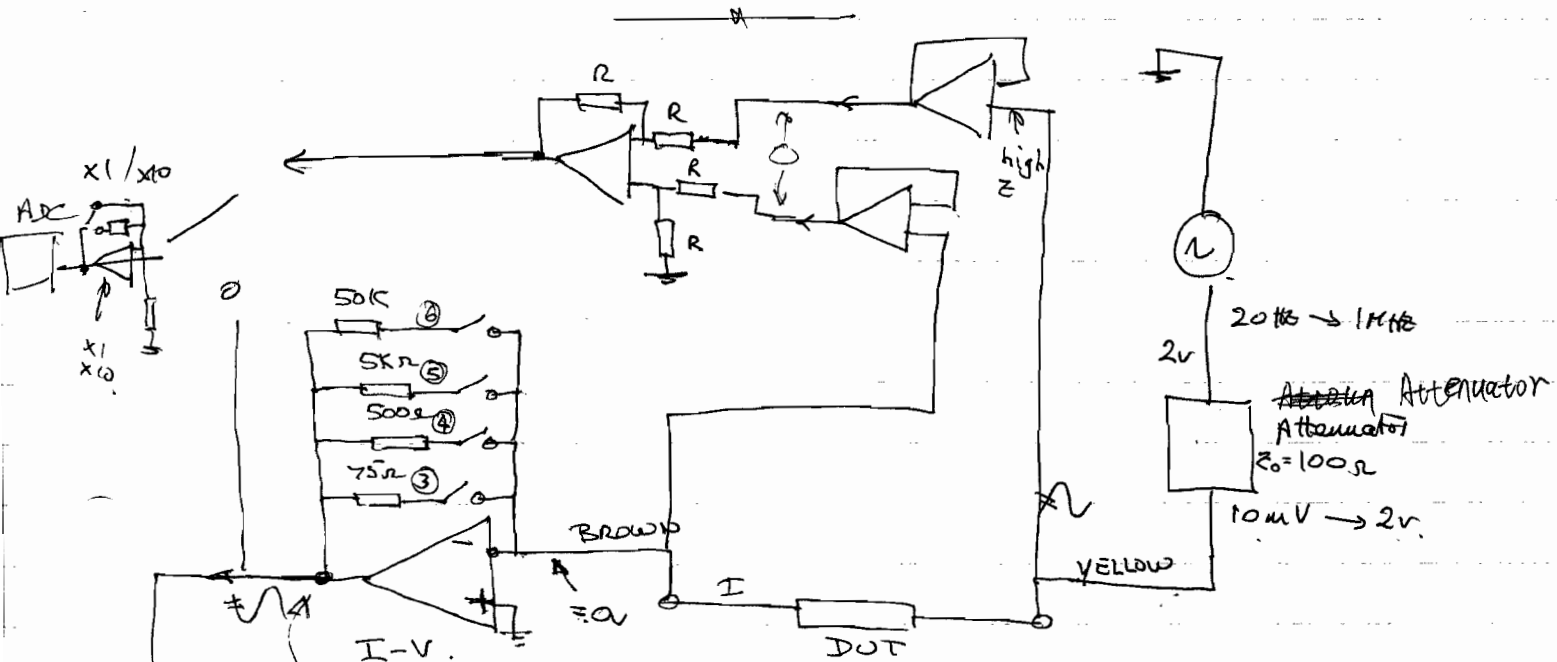

Measures current
 & gives voltage output
 I → V converter

$$\frac{V_{s/p}}{I} = \frac{O/C \text{ VOLTS}}{I/C \text{ CURRENT}}$$

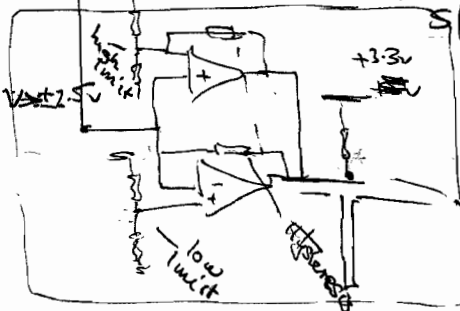

I-V over-range
 comparator
 over-range error
 (-ve) to M.P.

$$\text{Range 1} = 75\Omega \text{ (3)} + (x10)$$

$$\equiv \begin{cases} 2 = 75\Omega \text{ (3)} + 0 \\ 3 = 75\Omega \text{ (3)} + 0 \end{cases}$$

$$4 = 500 \text{ (4)} + 0$$

$$\text{PSEUDO 5} = 500\Omega \text{ (4)} + (x10)$$

$$5 = 5K \text{ (5)} + 0$$

$$\text{PSEUDO 6} = 5K \text{ (5)} + (x10)$$

$$6 = 50K \text{ (6)} + 0$$

$$7 = 50K \text{ (6)} + (x10)$$

RDC

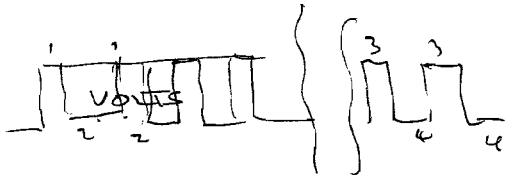
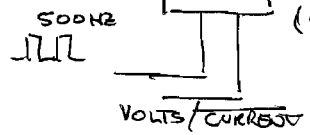
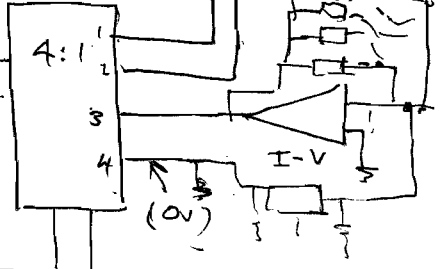
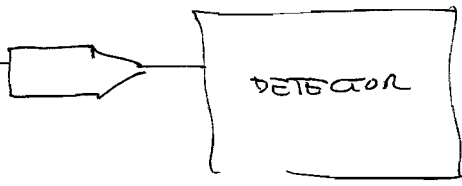
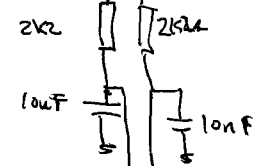
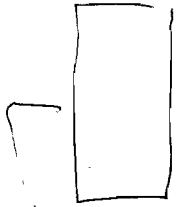
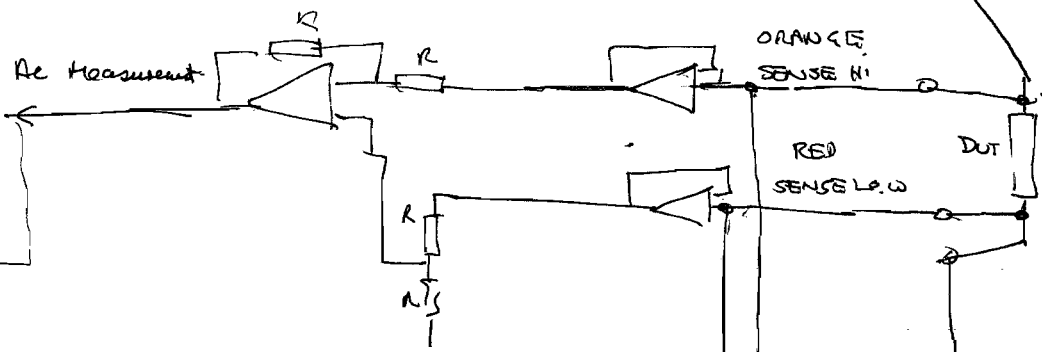
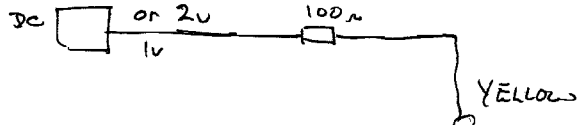

TP1 TP1

TP2 TP2

TP3 TP3 measure time

TP4 TP4 V and I measure time

TP10 TP5

TP6

TP7

TP8

TP9

TP10

TP11 - monitor stand resistor level $I-V$ (45)
o/p

TP12 Overload Comparator

TP13 Sense High amplitude o/p voltage

TP14 } 3:1

TP15 }

TP16 Sense Low Voltage

TP22 ripple rejection supply

TP19 and 20 detector output

TP17 bias overload comparator.

ALL FIRST OFFS MUST BE INSPECTED

- NOTE:
1. Fix Spacers and Washers to the False Front Panel in 8 positions.
 2. Add Double Sided Tape(Tesa 51968, Farnell 3069412) to both Flanges on the False Front Panel.

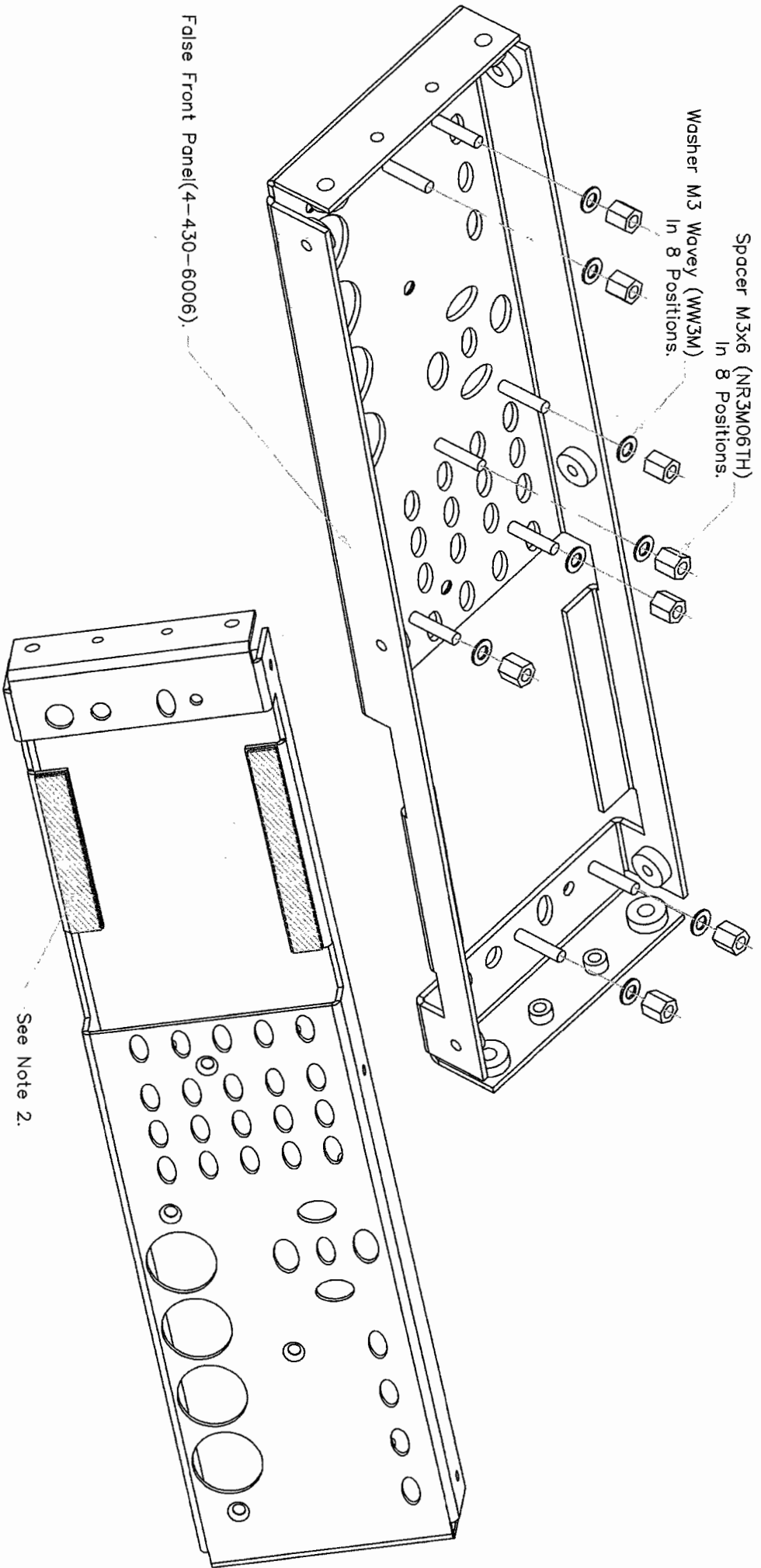

False Front Panel(4-430-6006).

Date	Dist	Ch.Note	Issue	Date	Dist	Ch.Note	Issue	 WAYNE KERR ELECTRONICS	Assy Title:	Inst Title:
01/11/09	BDS								FRONT PANEL ASSEMBLY	4100
				APPROVED.		CHECKED.		 DRAWN. BDS	Sheet 3 of 7 sheets	Drawing No: 5-410-7000-24

ALL FIRST OFFS MUST BE INSPECTED

- NOTE:
1. Position the LCD Display(LCSP10Q010) as shown and fix to the Double Sided Tape.
 2. To position the display correctly, dimension Gap A & Gap B must be equal, and the bottom edge of the display must be level with the bottom edge of the False Front Panel.

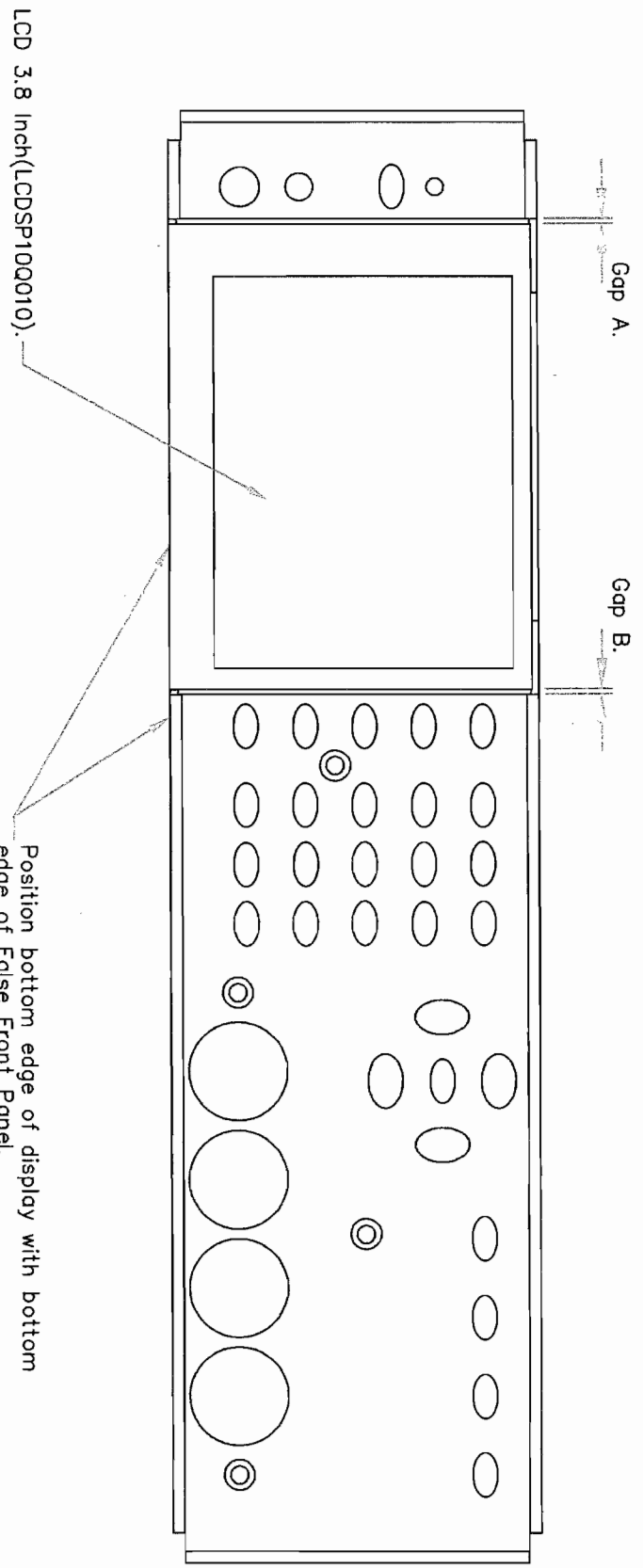

Date	Dist	Ch.Note	Issue	Date	Dist	Ch.Note	Issue	Assy Title:	Inst Title:
01/11/08	BDS		✓					FRONT PANEL ASSEMBLY	4100
				APPROVED.		CHECKED.		Sheet 4 of 7 sheets	Drawing No: 5-410-7000-24



DRAWN.
BDS

ALL FIRST OFFS MUST BE INSPECTED

- NOTE:
1. Remove protective film from the rear side of the clear window and the display.
 2. Fix the Front Panel Assembly to the False Front Panel Assembly, securing with M3 Nuts and Washers in 4 positions.
 3. Position so that GAP 'X' is equal and Gap 'Y' is equal.

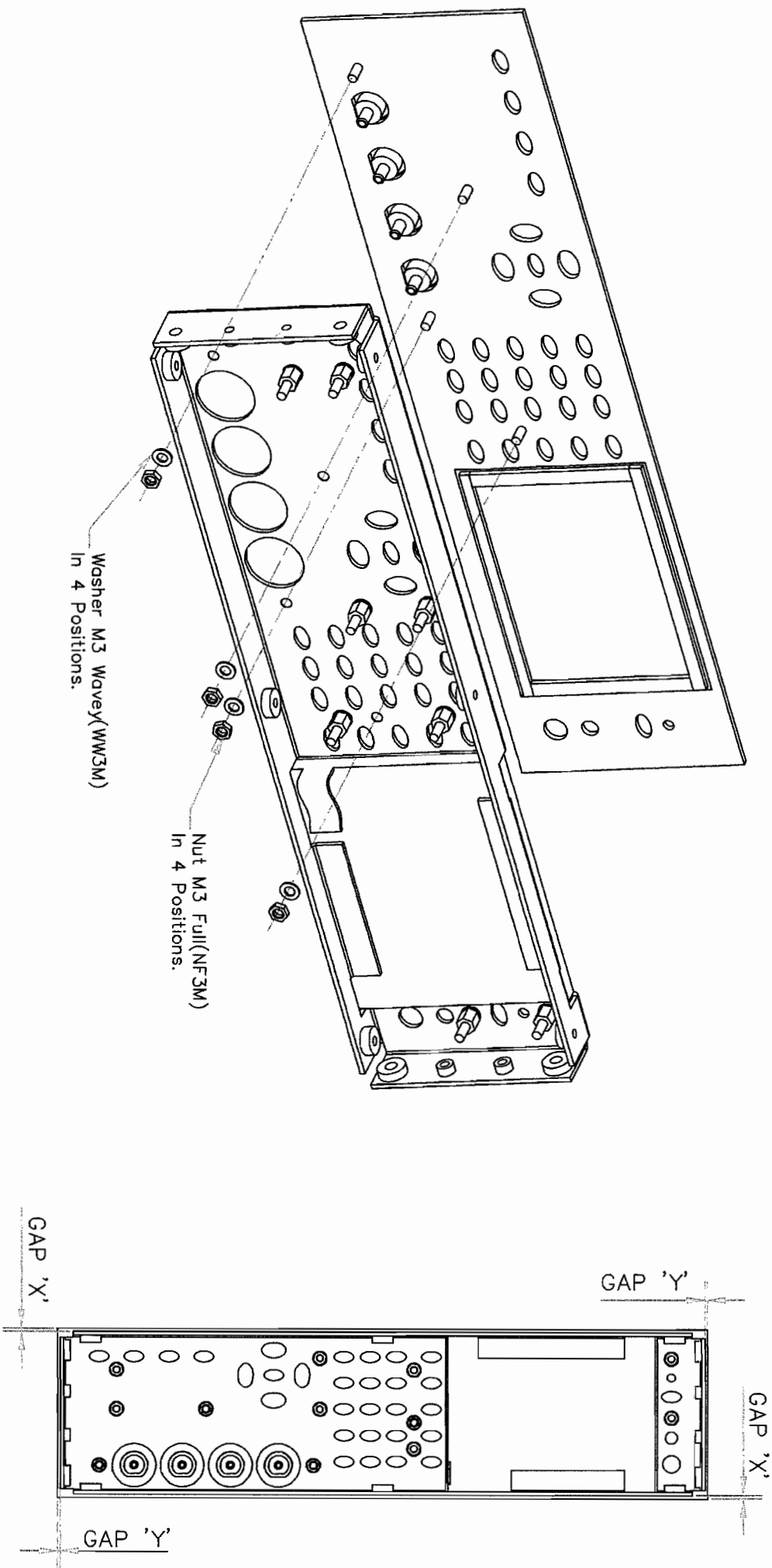

Date	Dist	Ch.Note	Issue	Date	Dist	Ch.Note	Issue	Assy Title:	Inst Title:
01/11/08	BDS							FRONT PANEL ASSEMBLY	4100
				APPROVED.		CHECKED.		Sheet 5 of 7 sheets	Drawing No: 5-410-7000-24





WAYNE KERR
ELECTRONICS

DRAWN.
BDS

ALL FIRST OFFS MUST BE INSPECTED

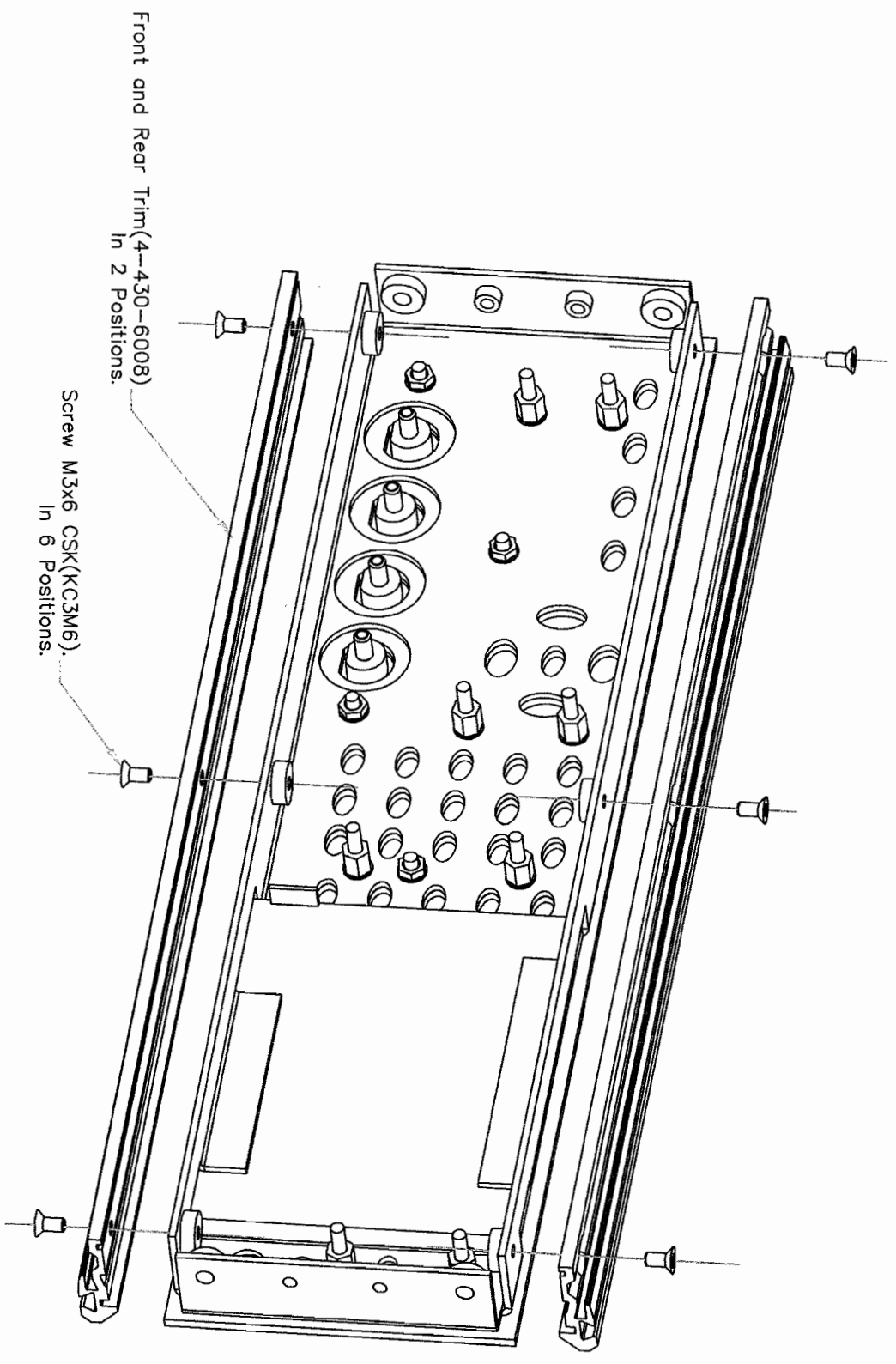
NOTE:
1. Fix Front and Rear Trims(4-430-6008) with M3x6 Screws.



Date	Dist	Ch.Note	Issue	Date	Dist	Ch.Note	Issue	 WAYNE KERR ELECTRONICS	Assy Title:	Inst Title:
01/11/08	BDS								FRONT PANEL ASSEMBLY	4100
				APPROVED.		CHECKED.		DRAWN.	Sheet 6 of 7 sheets	Drawing No:
								BDS		5-410-7000-24

ALL FIRST OFFS MUST BE INSPECTED

NOTE:
1. Fix Front and Rear Trims(4-430-6008) with M3x6 Screws.

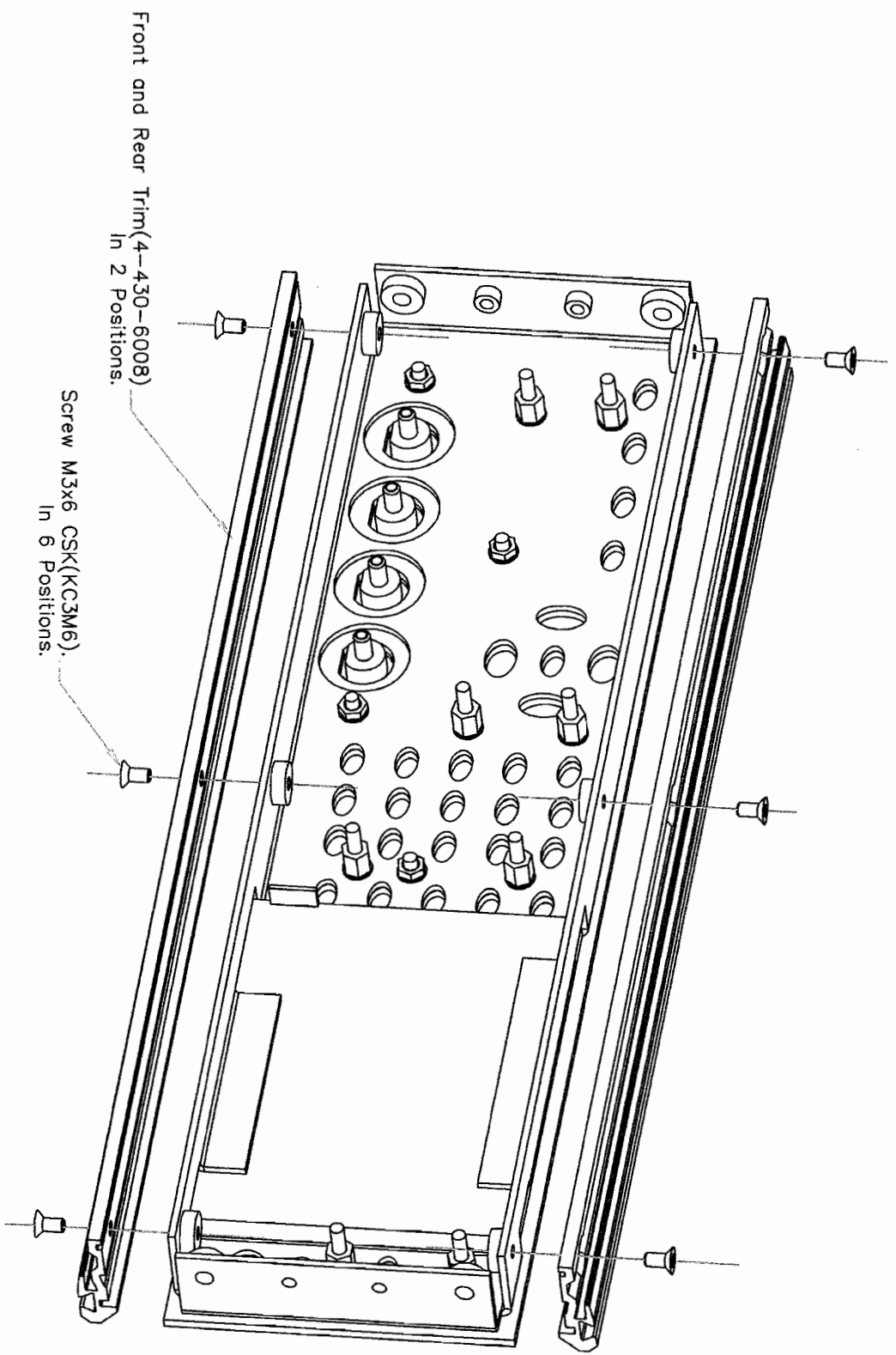

Date	Dist	Ch.Note	Issue	Date	Dist	Ch.Note	Issue	 WAYNE KERR ELECTRONICS	Assy Title:	Inst Title:
01/11/08	BDS								FRONT PANEL ASSEMBLY	4100
				APPROVED,		CHECKED,		DRAWN, <i>BDS</i>	Sheet 6 of 7 sheets	Drawing No: 5-410-7000-24

ALL FIRST OFFS MUST BE INSPECTED

NOTE:

1. Crop the Connector pins flush to the Board.
2. Push Buttons(4-643-6002 & 4-643-6003) onto the Keypad Assembly(5-430-1005) Switches.
3. Fit Keypad Assembly(5-430-1005) securing with Nuts and Washers in 8 positions.
4. Connect the Display Cable into the Keypad Connector as shown in Fig. 1.

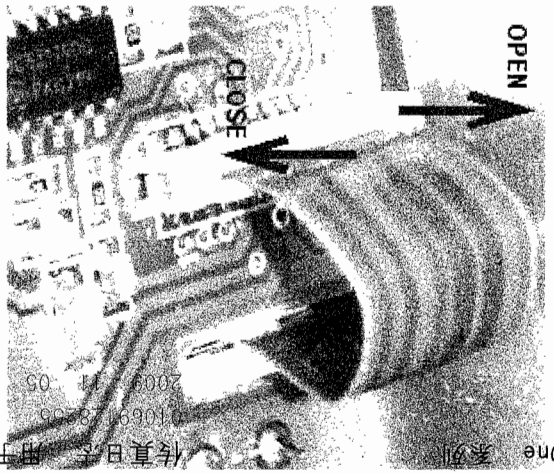
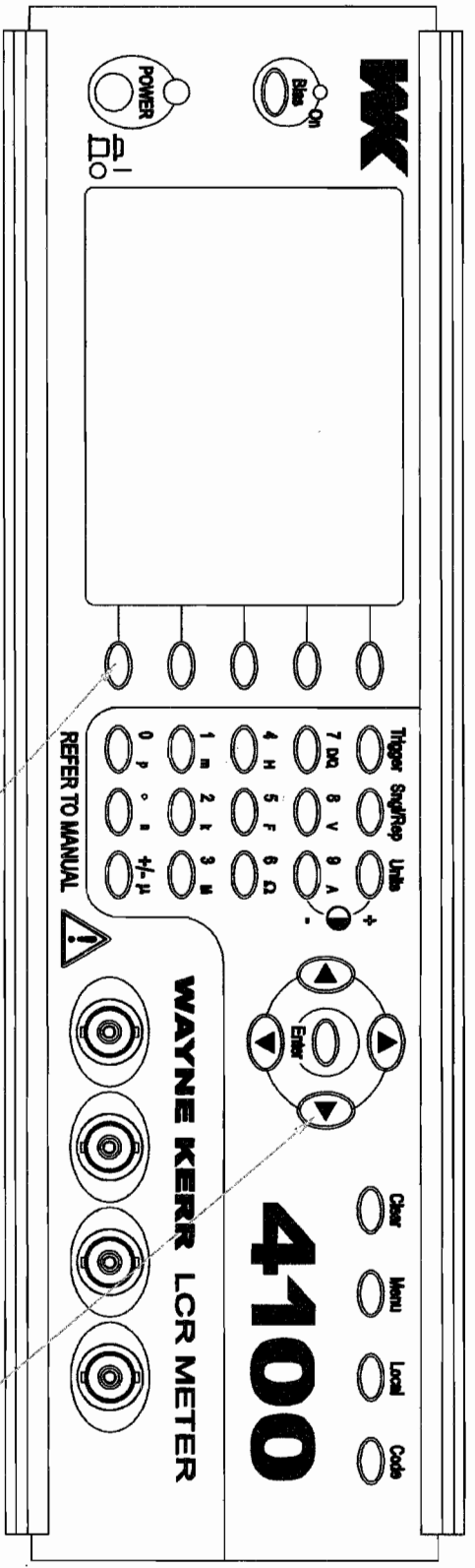
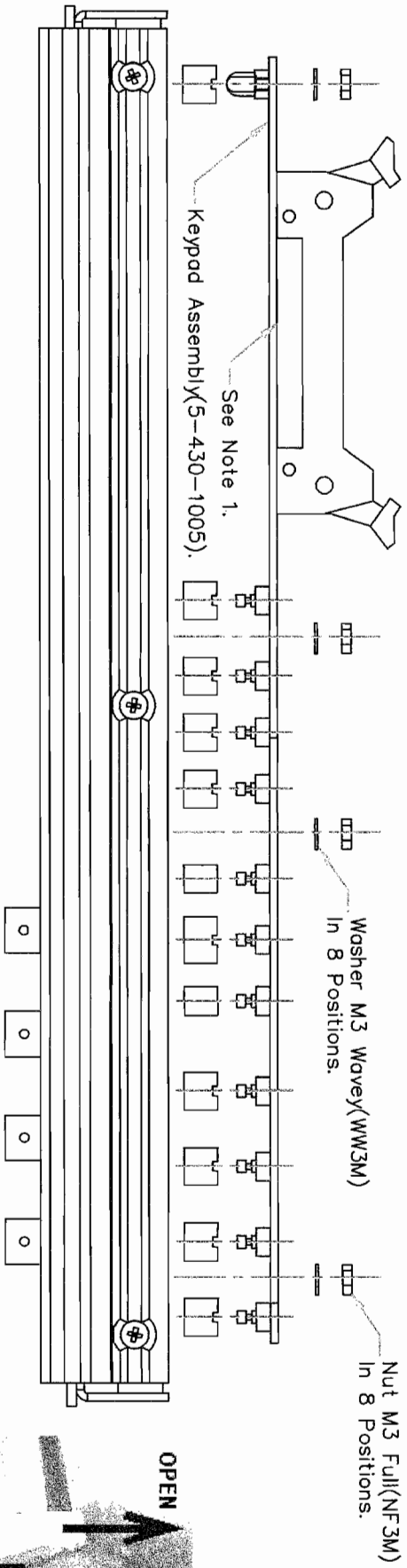

Fig. 1

Button Small(4-643-6002)
In 26 Positions.

Button Large(4-643-6003)
In 4 Positions.

Date	Dist	Ch.Note	Issue	Date	Dist	Ch.Note	Issue	<p>WAYNE KERR ELECTRONICS</p>	<p>ASSY Title:</p> <p>FRONT PANEL ASSEMBLY</p>	<p>Inst Title:</p> <p>4100</p>
01/11/09	BDS									
								<p>DRAWN:</p> <p>BDS</p>	<p>Sheet 7 of 7 sheets</p>	<p>Drawing No:</p> <p>5-410-7000-24</p>
								<p>APPROVED:</p> <p>CHECKED.</p>		

Indented Parts List for 5-410-7000 Issue A FRONT PANEL ASSEMBLY

Level	Item	Stock Code	Issue	Description	Quantity	Supplier Part Number	Supplier
1	1	5-430-1005	B	KEYPAD PCB ASSEMBLY	1		Not Specified
1	2	5-430-2000	B	COAX CABLE ASSEMBLY	4		Not Specified
1	3	4-410-6000	A	FRONT PANEL 4100	1		Not Specified
1	4	4-430-6006	A	FALSE FRONT PANEL	1		Not Specified
1	5	4-430-6008	A	FRONT & REAR TRIM	2		Not Specified
1	6	4-643-6002	P1	PUSH BUTTON SMALL	26		Hi-Tech Moulding
1	7	4-643-6003	P1	PUSH BUTTON LARGE	4		Hi-Tech Moulding
1	8	4-654-6021	A	WASHER M8 MODIFIED	1		Not Specified
1	9	LCSP10Q010		LCD DISPLAY 3.8 INCH MONO	1	SP10Q010	HITACHI
1	10	MT3259		FOAM TAPE 1.5 X 4 SINGLE SIDED	0.31	SCAPA 3259 1.5X4X50	Paratix Tapes & Conversions
1	11	NR3M06TH		SPACER M3 X 6MM THRD HEX	8		TR FASTENINGS LTD
				R30-1010602		R6331-02	Harwin PLC
						517-525	Farnell Electronic Components
						VIW1096	VITELEC ELECTRONICS LTD
1	12	WN1096		ISOLATING WASHER D HOLE	7		

End of Report

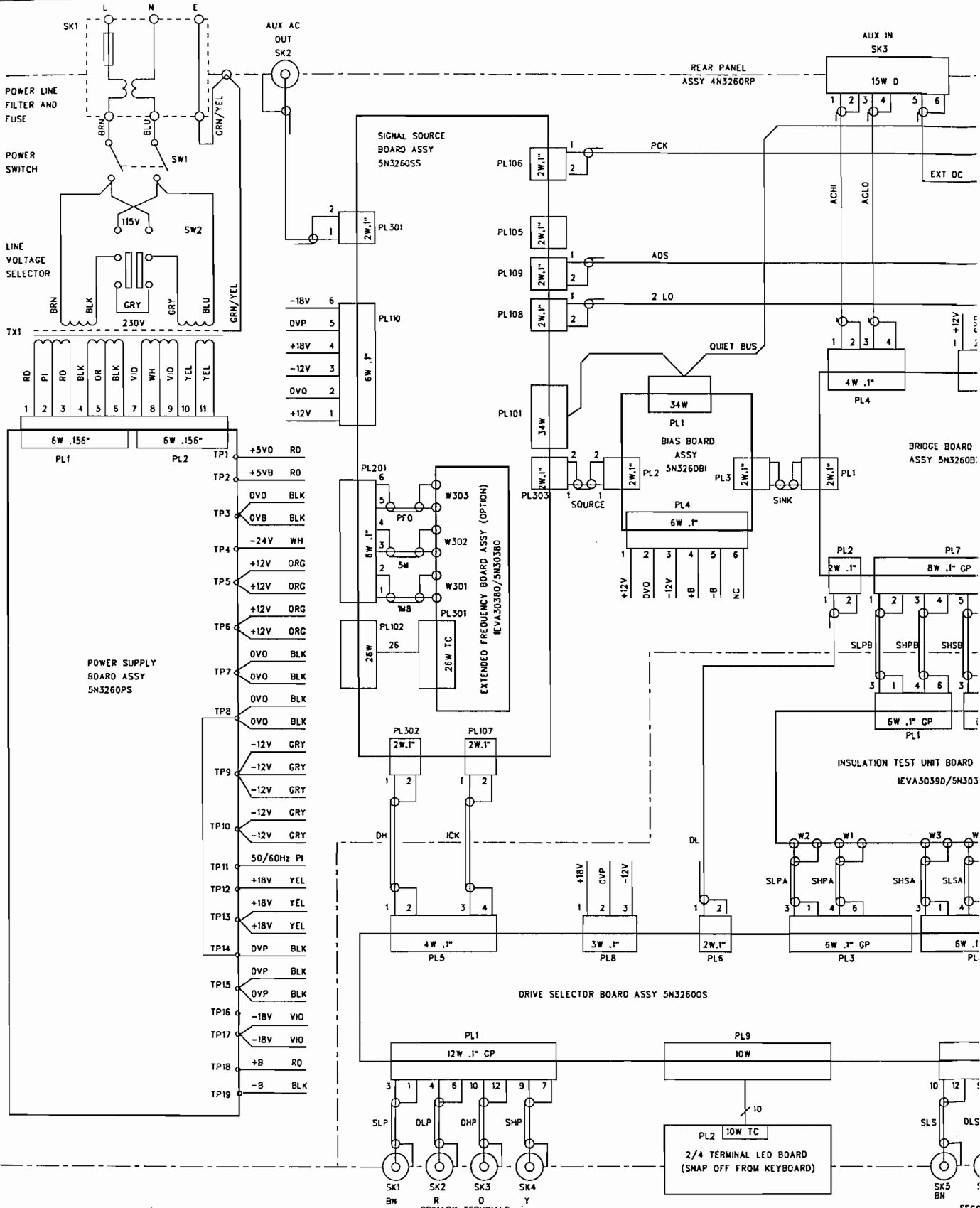

ISSUE	A	P2			
DATE	26.8.94	22/12/95			
MOD.No	-				
CHECKED	RB				
DRAWN	JN	JEC			

USED ON:
 1EVPWA326DA

NOTES:
 ALL CAPACITOR VALUES IN F
 ALL RESISTOR VALUES IN OHMS
 UNLESS OTHERWISE STATED

NOTES:
 1.TC=TRANSITION CONNECTOR
 2.CMC=COMMON MODE CHOKE
 3.GP= GOLD PLATE
 4.ALL BNC CONNECTORS AND SAFETY INTERLOCK ARE ISOLATED
 5.ALL OPTIONS ARE DESIGNED TO BE RETRO-FITTABLE
 6.IF ITU BOARD NOT FITTED, PL7 BRIDGE BOARD CONNECTS TO 7
 7.IF EXTENDED FREQUENCY BOARD NOT FITTED, PL5 BRIDGE CC
 PL2 DETECTOR BOARD HAS LINK FITTED BETWEEN PINS 1 AND 2

SECC

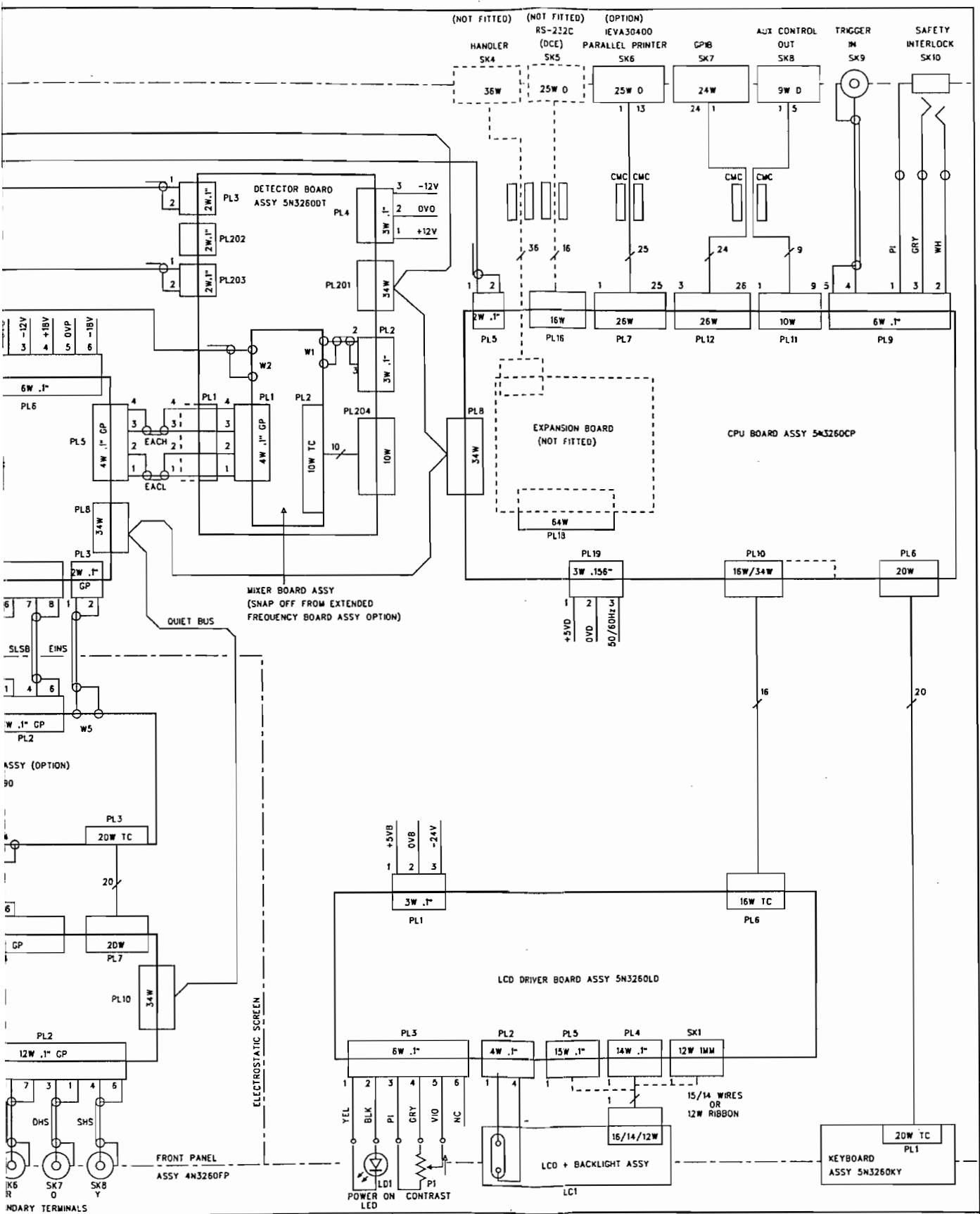

8.PL101 ON SIGNAL SOURCE BOARD HAS POLARITY REVERSED
(PIN 34 CONNECTS TO PIN 1 OF QUIET BUS RIBBON)



WAYNE KERR ELECTRONICS LIMITED
an Advantec International Group company

SANDBECK WAY, WETHERBY
YORKS, ENGLAND, LS22 7ON

FROM CHASSIS
PL3, PL4 DRIVE SELECTOR
CONNECTS TO PL1 DETECTOR BOARD

TITLE
INTERCONNECTION DIAGRAM

DRAWING No.
2SZV10003

2

© COPYRIGHT, ALL RIGHTS RESERVED

SHEET 1 OF 1 SHEETS